

# Section 2

## Molds

### for use with

# AWG Conductors & Bus Bar

Description .....	Page #
2.1 Cable to Cable Connections .....	33-41
2.2 Cable to Ground Rod Connections.....	42-48
2.3 CR-18 Wire-to-Ground Kits .....	49
2.4 Single Shot Connections (Cable to Ground Rod) .....	50-51
2.5 Ground Rod to Ground Rod Connections.....	52
2.6 Steel Stud to Steel Connections .....	52
2.7 Cable to Steel or Cast Iron Connections .....	53-61
2.8 Cable to Lug Connections.....	62-63
2.9 Cable to Copper Bus Bar Connections .....	64-70
2.10 Copper Bus Bar to Copper Bus Bar Connections.....	71-72
2.11 Copper Bus Bar to Steel Connections .....	73-74
2.12 Cable to Reinforcing Bar (Rebar) Connections .....	75-79
2.13 Single Shot Connections (Cable to Rebar) .....	80-81

















Section 2 - Molds  
AWG Conductors





































Connecting Power to Your World™



Section 2 - Molds  
AWG Conductors

Weld Type		Page #
	BB-1	71
	BB-2	72
	BB-3	72
	BS-1	73
	BS-2	73
	BS-3	74
	BS-4	74
	BS-5	74
	CB-1	62
	CB-2	65
	CB-3	67
	CB-4	64
	CB-5	70
	CB-6	66
	CB-7	68
	CB-29	69
	CB-33	63

Weld Type		Page #
	CC-1	33
	CC-2	34-35
	CC-4	36-37
	CC-6	38
	CC-7	39
	CC-11	41
	CC-14	33
	CC-34	40
	CR-1	42-43
	CR-2	44-45
	CR-3	46
	CR-17	47
	CR-18	49
	CR-24	48
	CRE-1	75
	CRE-2	76
	CRE-3	77
	CRE-4	78

Weld Type		Page #
	CRE-6	79
	CS-1	53
	CS-2	54
	CS-3	55-56
	CS-4	59
	CS-5	59
	CS-6	60
	CS-7	61
	CS-8	53
	CS-9	54
	CS-18	60
	CS-23	57-58
	RR-1	52
	RS-1	52
	RS-2	52
	Rebar Single Shots	80
	Single Shots	50

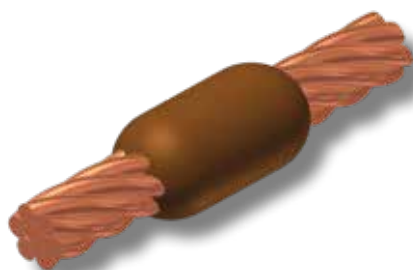

# CC-1

## TYPE MOLDS

*Horizontal End to End  
For AWG Conductors*

MOLDS FOR AWG CONDUCTORS										
Cable	STANDARD CONNECTION					HEAVY DUTY CONNECTION				
	Mold #	Price Key	Weld Metal*	Handle Clamps	Lead Time	Mold #	Price Key	Weld Metal	Handle Clamps	Lead Time
#8	M-6021	4	15	B-106	2	M-6021-H	4	32	B-106	4
#6	M-200	4	25	B-106	2	M-200-H	4	45	B-106	4
#4	M-201	4	25	B-106	2	M-201-H	4	45	B-106	2
#2	M-203	4	32	B-106	2	M-203-H	4	65	B-106	2
#1	M-204	4	32	B-106	4	M-204-H	4	65	B-106	4
1/0	M-205	4	45	B-106	2	M-205-H	4	90	B-106	2
2/0	M-206	4	65	B-106	SDS	M-206-H	4	115	B-106	2
3/0	M-207	4	90	B-106	2	M-207-H	4	150	B-106	2
4/0	M-208	4	90	B-106	SDS	M-208-H	4	150	B-106	2
250 MCM	M-209	4	115	B-106	2	M-209-H	4	200	B-106	2
300 MCM	M-210	4	115	B-106	2	M-210-H	4	200	B-106	2
350 MCM	M-211	4	150	B-106	2	M-211-H	4	250	B-106	2
500 MCM	M-213	4	200	B-106	2	M-213-H	5	2-150	B-107	2
750 MCM	M-214	5	2-150	B-107	2	M-214-H	5	500	B-107	2
1000 MCM	M-215	5	2-200	B-107	2	M-215-H	5	3-250	B-107	4

Section 2 - Molds  
AWG Conductors

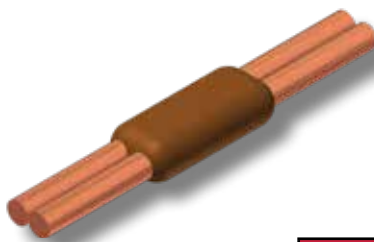

# CC-14

## TYPE MOLDS

*Horizontal Parallel through Cables  
For AWG Conductors*

MOLDS FOR AWG CONDUCTORS						
Cable		Mold #	Price Key	Weld Metal	Handle Clamps	Lead Time
Run	Tap					
#8	#8	M-5709	18†	15	40-4565-00	2
#6	#6	M-5618	18†	25	40-4565-00	2

- For sizes not listed, contact thermOweld®.
- Molds listed are for concentric stranded cable. Add suffix "-S" to mold number for solid conductors.
- For molds with wear plates, see page 135.
- For expedited service, contact thermOweld®.
- To order weld metal for use with EZ Lite Remote® insert TW before and EZ after weld metal number.
- Required Tools;
  - Handle Clamps w/ Flint Ignitor (see chart for correct handles)
  - 38-0309-00 ~ Flint Ignitor or 38-EZLT-RU ~ EZ Lite Remote®
  - † ~ Sold complete with handles
- Other recommended accessories;
  - 40-0319-01 ~ Mold Cleaner for cartridge sizes #15-#65
  - 40-0319-03 ~ Mold Cleaner for cartridge sizes #90-#500
  - 38-3922-00 ~ Mold Cleaning Brush
  - 38-0135-00 ~ Cable Cleaning Brush
  - 38-0330-00 ~ Cable Clamp

## CC-2

### TYPE MOLDS

Horizontal Cable Tap to Horizontal Cable Run  
For AWG Conductors

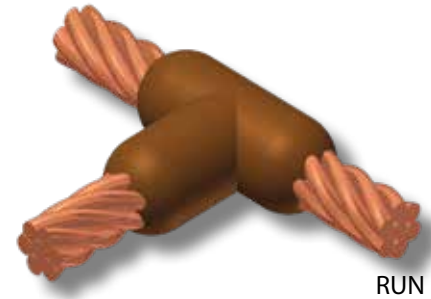

MOLDS FOR AWG CONDUCTORS											
Cable		STANDARD CONNECTION					HEAVY DUTY CONNECTION				
Run	Tap	Mold #	Price Key	Weld Metal	Handle Clamps	Lead Time	Mold #	Price Key	Weld Metal	Handle Clamps	Lead Time
#6	#6	M-5072	4	32	B-106	2	M-5072-H	4	45	B-106	4
#4	#4	M-221	4	32	B-106	2	M-221-H	4	65	B-106	2
#2	#2	M-223	4	45	B-106	SDS	M-223-H	4	65	B-106	2
	#4	M-224	4	45	B-106	2	M-224-H	4	65	B-106	2
#1	#1	M-225	4	45	B-106	2	M-225-H	4	65	B-106	4
	#2	M-226	4	45	B-106	2	M-226-H	4	65	B-106	4
	#4	M-227	4	45	B-106	2	M-227-H	4	65	B-106	4
1/0	1/0	M-228	4	90	B-106	SDS	M-228-H	4	115	B-106	2
	#1	M-229	4	45	B-106	2	M-229-H	4	90	B-106	4
	#2	M-230	4	45	B-106	2	M-230-H	4	90	B-106	2
	#2 Sol	M-5311	4	45	B-106	2	M-5311-H	4	90	B-106	2
	#4	M-231	4	45	B-106	2	M-231-H	4	65	B-106	2
2/0	4/0	M-5059	4	90	B-106	SDS	M-5059-H	4	150	B-106	2
	2/0	M-232	4	90	B-106	SDS	M-232-H	4	115	B-106	2
	1/0	M-233	4	90	B-106	2	M-233-H	4	115	B-106	2
	#1	M-234	4	45	B-106	2	M-234-H	4	90	B-106	2
	#2	M-235	4	45	B-106	SDS	M-235-H	4	90	B-106	2
	#2 Sol	M-8093	4	45	B-106	2	M-8093-H	4	90	B-106	2
#4	M-5475	4	45	B-106	2	M-5475-H	4	65	B-106	2	
3/0	3/0	M-236	4	115	B-106	SDS	M-236-H	4	200	B-106	2
	2/0	M-237	4	90	B-106	2	M-237-H	4	150	B-106	2
	1/0	M-238	4	90	B-106	2	M-238-H	4	150	B-106	4
	#1	M-239	4	45	B-106	2	M-239-H	4	90	B-106	4
	#2	M-240	4	45	B-106	2	M-240-H	4	90	B-106	4
	#2 Sol	M-5884	4	45	B-106	2	M-5884-H	4	90	B-106	2
	#4	M-5574	4	45	B-106	2	M-5574-H	4	65	B-106	2
4/0	500 MCM	M-5010	4	150	B-106	4	M-5010-H	5	2 x150	B-106	4
	4/0	M-241	4	150	B-106	SDS	M-241-H	4	250	B-106	2
	3/0	M-242	4	115	B-106	2	M-242-H	4	200	B-106	4
	2/0	M-243	4	90	B-106	SDS	M-243-H	4	150	B-106	2
	1/0	M-244	4	90	B-106	SDS	M-244-H	4	150	B-106	2
	#1	M-245	4	90	B-106	2	M-245-H	4	150	B-106	2
	#2	M-246	4	90	B-106	SDS	M-246-H	4	150	B-106	2
	#2 Sol	M-5348	4	90	B-106	2	M-5348-H	4	150	B-106	2
	#4	M-5021	4	90	B-106	2	M-5021-H	4	150	B-106	2
250 MCM	250 MCM	M-247	4	150	B-106	SDS	M-247-H	4	250	B-106	2
	4/0	M-248	4	150	B-106	2	M-248-H	4	250	B-106	2
	3/0	M-249	4	150	B-106	2	M-249-H	4	250	B-106	4
	2/0	M-250	4	90	B-106	2	M-250-H	4	150	B-106	2
	1/0	M-251	4	90	B-106	2	M-251-H	4	150	B-106	4
	#1	M-252	4	90	B-106	2	M-252-H	4	150	B-106	4
	#2	M-253	4	90	B-106	2	M-253-H	4	150	B-106	4

Section 2 - Molds  
AWG Conductors

CC-2

TYPE MOLDS

Horizontal Cable Tap to Horizontal Cable Run  
For AWG Conductors

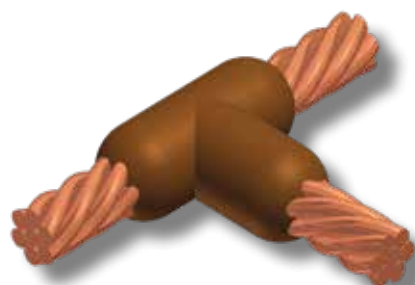

RUN

TAP

MOLDS FOR AWG CONDUCTORS											
Cable		STANDARD CONNECTION					HEAVY DUTY CONNECTION				
Run	Tap	Mold #	Price Key	Weld Metal	Handle Clamps	Lead Time	Mold #	Price Key	Weld Metal	Handle Clamps	Lead Time
300 MCM	300 MCM	M-254	4	200	B-106	2	M-254-H	5	2-150	B-107	2
	250 MCM	M-255	4	150	B-106	2	M-255-H	4	250	B-106	4
	4/0	M-256	4	150	B-106	2	M-256-H	4	250	B-106	4
	3/0	M-257	4	150	B-106	2	M-257-H	4	250	B-106	4
	2/0	M-258	4	90	B-106	2	M-258-H	4	150	B-106	4
	1/0	M-259	4	90	B-106	2	M-259-H	4	150	B-106	4
	#1	M-260	4	90	B-106	2	M-260-H	4	150	B-106	4
#2	M-261	4	90	B-106	2	M-261-H	4	150	B-106	4	
350 MCM	350 MCM	M-262	4	200	B-106	2	M-262-H	5	2-150	B-107	4
	300 MCM	M-263	4	200	B-106	2	M-263-H	5	2-150	B-107	4
	250 MCM	M-264	4	200	B-106	2	M-264-H	5	2-150	B-107	4
	4/0	M-265	4	150	B-106	2	M-265-H	4	250	B-106	2
	3/0	M-266	4	150	B-106	2	M-266-H	4	250	B-106	4
	2/0	M-267	4	90	B-106	2	M-267-H	4	150	B-106	4
	1/0	M-268	4	90	B-106	2	M-268-H	4	150	B-106	2
#1	M-269	4	90	B-106	2	M-269-H	4	150	B-106	4	
#2	M-270	4	90	B-106	2	M-270-H	4	150	B-106	4	
500 MCM	500 MCM	M-280	4	2-150	B-106	SDS	M-280-H	5	500	B-107	2
	350 MCM	M-282	4	200	B-106	2	M-282-H	5	2-150	B-107	4
	300 MCM	M-283	4	200	B-106	2	M-283-H	5	2-150	B-107	4
	250 MCM	M-284	4	200	B-106	2	M-284-H	5	2-150	B-107	2
	4/0	M-285	4	150	B-106	2	M-285-H	4	250	B-106	2
	2/0	M-286	4	90	B-106	2	M-286-H	4	150	B-106	2
	1/0	M-287	4	90	B-106	2	M-287-H	4	150	B-106	2
#1	M-288	4	90	B-106	2	M-288-H	4	150	B-106	4	
#2	M-289	4	90	B-106	2	M-289-H	4	150	B-106	2	
750 MCM	750 MCM	M-290	5	500	B-107	2	M-290-H	5	3-250	B-107	2
	500 MCM	M-291	5	2-200	B-107	2	M-291-H	5	3-200	B-107	4
	350 MCM	M-293	4	250	B-106	2	M-293-H	5	2-200	B-107	4
	300 MCM	M-294	4	200	B-106	2	M-294-H	5	2-150	B-107	4
	250 MCM	M-295	4	200	B-106	2	M-295-H	5	2-150	B-107	4
	4/0	M-296	4	150	B-106	2	M-296-H	4	250	B-106	4
	2/0	M-297	4	150	B-106	2	M-297-H	4	250	B-106	4
1/0	M-298	4	150	B-106	2	M-298-H	4	250	B-106	4	

- For sizes not listed, contact thermOweld®.
- Molds listed are for concentric stranded cable. Add suffix "-S" to mold number for solid conductors.
- For molds with wear plates, see page 135.
- For expedited service, contact thermOweld®.
- To order weld metal for use with EZ Lite Remote® insert TW before and EZ after weld metal number.
- Required Tools;
  - Handle Clamps w/ Flint Ignitor (see chart for correct handles)
  - 38-0309-00 ~ Flint Ignitor or 38-EZLT-RU EZ Lite Remote®
- Other recommended accessories;
  - 40-0319-01 ~ Mold Cleaner for cartridge sizes #15-#65
  - 40-0319-03 ~ Mold Cleaner for cartridge sizes #90-#500
  - 38-3922-00 ~ Mold Cleaning Brush
  - 38-0135-00 ~ Cable Cleaning Brush
  - 38-0330-00 ~ Cable Clamp

Section 2 - Molds  
AWG Conductors

## CC-4

### TYPE MOLDS

Horizontal to Horizontal Cable Cross

For AWG Conductors

Tap cable is cut

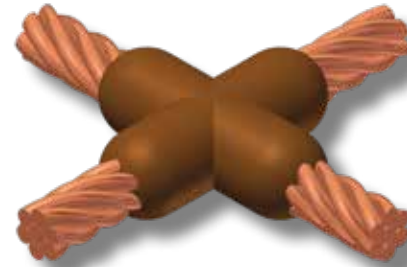

MOLDS FOR AWG CONDUCTORS											
Cable		STANDARD CONNECTION					HEAVY DUTY CONNECTION				
Run	Tap	Mold #	Price Key	Weld Metal	Handle Clamps	Lead Time	Mold #	Price Key	Weld Metal	Handle Clamps	Lead Time
#6	#6	M-5001	4	32	B-106	2	M-5001-H	4	65	B-106	4
#4	#4	M-423	4	45	B-106	2	M-423-H	4	65	B-106	2
#2	#2	M-425	4	65	B-106	2	M-425-H	4	90	B-106	4
	#4	M-426	4	65	B-106	2	M-426-H	4	90	B-106	4
#1	#1	M-427	4	65	B-106	2	M-427-H	4	115	B-106	4
	#2	M-428	4	65	B-106	2	M-428-H	4	115	B-106	4
	#4	M-429	4	65	B-106	4	M-429-H	4	115	B-106	4
1/0	1/0	M-430	4	90	B-106	2	M-430-H	4	150	B-106	2
	#1	M-431	4	90	B-106	4	M-431-H	4	150	B-106	4
	#2	M-432	4	90	B-106	2	M-432-H	4	150	B-106	4
	#4	M-433	4	90	B-106	2	M-433-H	4	150	B-106	2
2/0	2/0	M-434	4	115	B-106	SDS	M-434-H	4	200	B-106	2
	1/0	M-435	4	115	B-106	2	M-435-H	4	200	B-106	4
	#1	M-436	4	115	B-106	4	M-436-H	4	200	B-106	4
	#2	M-437	4	115	B-106	2	M-437-H	4	150	B-106	4
3/0	3/0	M-438	4	150	B-106	2	M-438-H	4	250	B-106	2
	2/0	M-439	4	150	B-106	2	M-439-H	4	250	B-106	4
	1/0	M-440	4	115	B-106	2	M-440-H	4	200	B-106	4
	#1	M-441	4	115	B-106	2	M-441-H	4	200	B-106	4
	#2	M-442	4	115	B-106	2	M-442-H	4	200	B-106	4
4/0	4/0	M-443	4	200	B-106	SDS	M-443-H	5	2-150	B-107	2
	3/0	M-444	4	200	B-106	2	M-444-H	5	2-150	B-107	4
	2/0	M-445	4	150	B-106	2	M-445-H	4	250	B-106	2
	1/0	M-446	4	150	B-106	2	M-446-H	4	250	B-106	4
	#1	M-447	4	115	B-106	2	M-447-H	4	200	B-106	4
	#2	M-448	4	115	B-106	2	M-448-H	4	200	B-106	4
250 MCM	250 MCM	M-449	4	200	B-106	2	M-449-H	5	2-150	B-107	4
	4/0	M-450	4	200	B-106	2	M-450-H	5	2-150	B-107	4
	3/0	M-451	4	200	B-106	2	M-451-H	5	2-150	B-107	4
	2/0	M-452	4	150	B-106	2	M-452-H	4	250	B-106	4
	1/0	M-453	4	150	B-106	2	M-453-H	4	250	B-106	4
	#1	M-454	4	115	B-106	4	M-454-H	4	200	B-106	4
	#2	M-455	4	115	B-106	2	M-455-H	4	200	B-106	4

- For sizes not listed, contact thermOweld®.
- Molds listed are for concentric stranded cable. Add suffix "-S" to mold number for solid conductors.
- For expedited service, contact thermOweld®.
- To order weld metal for use with EZ Lite Remote® insert TW before and EZ after weld metal number.
- Required Tools;
  - Handle Clamps w/ Flint Ignitor (see chart for correct handles)
  - 38-0309-00 ~ Flint Ignitor or 38-EZLT-RU EZ Lite Remote®
- Other recommended accessories;
  - 40-0319-01 ~ Mold Cleaner for cartridge sizes #15-#65
  - 40-0319-03 ~ Mold Cleaner for cartridge sizes #90-#500
  - 38-3922-00 ~ Mold Cleaning Brush
  - 38-0135-00 ~ Cable Cleaning Brush
  - 38-0330-00 ~ Cable Clamp

Section 2 - Molds  
AWG Conductors



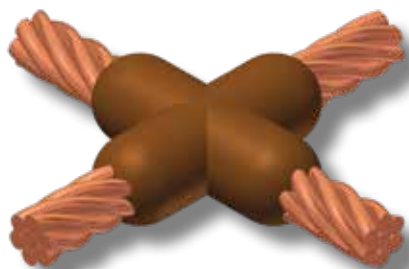

# CC-4

## TYPE MOLDS

*Horizontal to Horizontal Cable Cross  
For AWG Conductors  
Tap cable is cut*

Section 2 - Molds  
AWG Conductors

MOLDS FOR AWG CONDUCTORS											
Cable		STANDARD CONNECTION					HEAVY DUTY CONNECTION				
Run	Tap	Mold #	Price Key	Weld Metal	Handle Clamps	Lead Time	Mold #	Price Key	Weld Metal	Handle Clamps	Lead Time
300 MCM	300 MCM	M-456	4	250	B-106	2	M-456-H	5	2-200	B-107	4
	250 MCM	M-457	4	250	B-106	4	M-457-H	5	2-200	B-107	4
	4/0	M-458	4	200	B-106	4	M-458-H	5	2-150	B-107	4
	3/0	M-459	4	200	B-106	2	M-459-H	5	2-150	B-107	4
	2/0	M-460	4	150	B-106	4	M-460-H	4	250	B-106	4
	1/0	M-461	4	150	B-106	4	M-461-H	4	250	B-106	4
	#1	M-462	4	115	B-106	4	M-462-H	4	200	B-106	4
	#2	M-463	4	115	B-106	2	M-463-H	4	200	B-106	4
350 MCM	350 MCM	M-464	4	250	B-106	2	M-464-H	5	2-200	B-107	4
	300 MCM	M-465	4	250	B-106	4	M-465-H	5	2-200	B-107	4
	250 MCM	M-466	4	250	B-106	2	M-466-H	5	2-200	B-107	4
	4/0	M-467	4	200	B-106	2	M-467-H	5	2-150	B-107	4
	3/0	M-468	4	200	B-106	4	M-468-H	5	2-150	B-107	4
	2/0	M-469	4	200	B-106	2	M-469-H	5	2-150	B-107	2
	1/0	M-470	4	200	B-106	4	M-470-H	5	2-150	B-107	4
	#1	M-471	4	150	B-106	4	M-471-H	4	250	B-106	4
#2	M-472	4	150	B-106	4	M-472-H	4	250	B-106	4	
500 MCM	500 MCM	M-483	5	500	B-107	2	M-483-H	5	3-250	B-107	2
	350 MCM	M-485	5	2-200	B-107	4	M-485-H	5	3-200	B-107	4
	300 MCM	M-486	5	2-200	B-107	2	M-486-H	5	3-200	B-107	4
	250 MCM	M-487	5	2-150	B-107	4	M-487-H	5	500	B-107	4
	4/0	M-488	5	2-150	B-107	2	M-488-H	5	500	B-107	2
	3/0	M-489	5	2-150	B-107	4	M-489-H	5	500	B-107	4
	2/0	M-490	4	250	B-106	2	M-490-H	5	2-200	B-107	4
	1/0	M-491	4	250	B-106	2	M-491-H	5	2-200	B-107	4
	#1	M-492	4	200	B-106	4	M-492-H	5	2-150	B-107	4
	#2	M-493	4	200	B-106	2	M-493-H	5	2-150	B-107	2

- For sizes not listed, contact thermOweld®.
- Molds listed are for concentric stranded cable. Add suffix "-S" to mold number for solid conductors.
- For expedited service, contact thermOweld®.
- To order weld metal for use with EZ Lite Remote® insert TW before and EZ after weld metal number.
- Required Tools;
  - Handle Clamps w/ Flint Ignitor (see chart for correct handles)
  - 38-0309-00 ~ Flint Ignitor or 38-EZLT-RU EZ Lite Remote®
- Other recommended accessories;
  - 40-0319-01 ~ Mold Cleaner for cartridge sizes #15-#65
  - 40-0319-03 ~ Mold Cleaner for cartridge sizes #90-#500
  - 38-3922-00 ~ Mold Cleaning Brush
  - 38-0135-00 ~ Cable Cleaning Brush
  - 38-0330-00 ~ Cable Clamp

## CC-6

### TYPE MOLDS

*Horizontal Parallel Tap*  
For AWG Conductors

Section 2 - Molds  
AWG Conductors

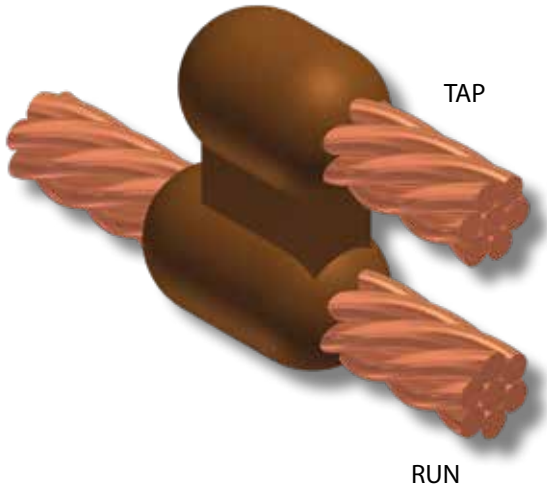

MOLDS FOR AWG CONDUCTORS						
Cable		Mold #	Price Key	Weld Metal	Handle Clamps	Lead Time
Run	Tap					
#6 Sol	#6 Sol	M-1270	4	25	B-106	2
#6	#6	M-1271	4	25	B-106	2
#4	#4	M-1272	4	32	B-106	2
	#6	M-1273	4	32	B-106	2
	#6 Sol	M-1274	4	32	B-106	4
	#8 Sol	M-1275	4	32	B-106	2
#2	#2	M-1276	4	65	B-106	2
	#2	M-1276-S	4	65	B-106	SDS
	#4	M-1277	4	45	B-106	4
	#6	M-1278	4	32	B-106	2
	#6 Sol	M-1279	4	32	B-106	2
	#8 Sol	M-1280	4	32	B-106	2
#1	#1	M-1281	4	65	B-106	2
	#2	M-1282	4	65	B-106	2
	#4	M-1283	4	45	B-106	4
	#6	M-1284	4	45	B-106	2
	#6 Sol	M-1285	4	45	B-106	4
	#8 Sol	M-1286	4	46	B-106	4
1/0	1/0	M-1287	4	90	B-106	2
	#1	M-1288	4	90	B-106	4
	#2	M-1289	4	65	B-106	2
	#4	M-1290	4	65	B-106	2
	#6	M-1291	4	45	B-106	2
	#6 Sol	M-1292	4	45	B-106	2
	#8 Sol	M-1293	4	45	B-106	2
2/0	2/0	M-1294	4	115	B-106	2
	1/0	M-1295	4	115	B-106	2
	#1	M-1296	4	90	B-106	4
	#2	M-1297	4	90	B-106	2
	#4	M-1298	4	65	B-106	2
	#6	M-1299	4	65	B-106	2
	#6 Sol	M-1300	4	65	B-106	2
	#8 Sol	M-1301	4	65	B-106	2
4/0	4/0	M-1302	4	150	B-106	2
	2/0	M-1303	4	115	B-106	2
	1/0	M-1304	4	115	B-106	2
	#1	M-1305	4	115	B-106	2
	#2	M-1306	4	115	B-106	2
	#4	M-1307	4	90	B-106	2
	#6	M-1308	4	90	B-106	2
	#6 Sol	M-1309	4	90	B-106	2
	#8 Sol	M-1310	4	90	B-106	2

- For sizes not listed, contact thermOweld®.
- Molds listed are for concentric stranded cable. Add suffix "-S" to mold number for solid conductors.
- For heavy duty connections, contact thermOweld®.
- For molds with wear plates, see page 135.
- For expedited service, contact thermOweld®.
- To order weld metal for use with EZ Lite Remote® insert TW before and EZ after weld metal number.
- Required Tools;
  - Handle Clamps w/ Flint Ignitor (see chart for correct handles)
  - 38-0309-00 ~ Flint Ignitor or 38-EZLT-RU EZ Lite Remote®
- Other recommended accessories;
  - 40-0319-01 ~ Mold Cleaner for cartridge sizes #15-#65
  - 40-0319-03 ~ Mold Cleaner for cartridge sizes #90-#500
  - 38-3922-00 ~ Mold Cleaning Brush
  - 38-0135-00 ~ Cable Cleaning Brush
  - 38-0330-00 ~ Cable Clamp



CC-7

TYPE MOLDS

Horizontal Parallel through Cables  
For AWG Conductors

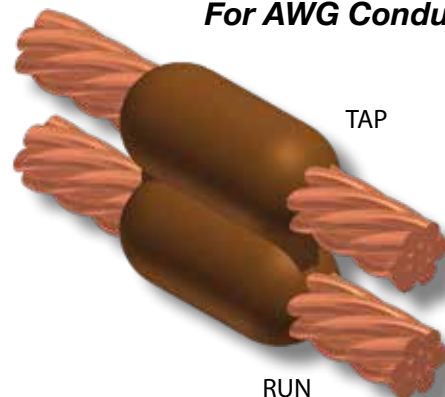

MOLDS FOR AWG CONDUCTORS						
Cable		Mold #	Price Key	Weld Metal	Handle Clamps	Lead Time
Run	Tap					
#6	#6	M-5965	4	25	B-106	2
#4	#4	M-1311	4	32	B-106	2
	#6	M-5627	4	32	B-106	2
	#6 Sol	M-8882	4	32	B-106	2
	#8	M-5629	4	32	B-106	4
#2	#8 Sol	M-5630	4	32	B-106	2
	#2	M-1313	4	65	B-106	2
	#2 Sol	M-6654	4	65	B-106	SDS
	#4	M-1314	4	65	B-106	2
	#6	M-5631	4	45	B-106	2
	#6 Sol	M-5632	4	45	B-106	2
	#8	M-5634	4	45	B-106	2
#1	#8 Sol	M-5635	4	45	B-106	4
	#1	M-1315	4	65	B-106	2
	#2	M-1316	4	65	B-106	2
	#4	M-1317	4	65	B-106	4
	#6	M-5636	4	65	B-106	4
	#6 Sol	M-5637	4	65	B-106	4
	#8	M-5638	4	45	B-106	4
	#8 Sol	M-5639	4	45	B-106	4
1/0	1/0	M-1318	4	90	B-106	2
	#1	M-1319	4	65	B-106	4
	#2	M-1320	4	65	B-106	2
	#4	M-1321	4	65	B-106	2
	#6	M-5642	4	65	B-106	2
	#6 Sol	M-1208	4	65	B-106	2
	#8	M-5644	4	65	B-106	4
	#8 Sol	M-5645	4	65	B-106	2
	#2 Sol	#2	M-5973	4	65	B-106
2/0	2/0	M-1322	4	115	B-106	SDS
	1/0	M-1323	4	115	B-106	2
	#1	M-1324	4	90	B-106	2
	#2	M-1325	4	90	B-106	2
	#2 Sol	M-8289	4	90	B-106	4
	#4	M-5659	4	90	B-106	2
	#6	M-5342	4	90	B-106	2
	#6 Sol	M-5652	4	90	B-106	2
	#8	M-5668	4	65	B-106	4
	#8 Sol	M-5943	4	65	B-106	2
4/0	4/0	M-1331	4	200	B-106	SDS
	3/0	M-1332	4	200	B-106	2
	2/0	M-1333	4	150	B-106	2
	1/0	M-1334	4	150	B-106	2
	1/0 Sol	M-2551	4	150	B-106	4
	#1	M-1335	4	150	B-106	2
	#2	M-1336	4	150	B-106	2
	#2 Sol	M-6805	4	150	B-106	4
	#4	M-5340	4	150	B-106	2
	#6	M-5684	4	90	B-106	2
	#6 Sol	M-6552	4	90	B-106	2
	#8	M-5686	4	90	B-106	4
	#8 Sol	M-5688	4	90	B-106	2
250 MCM	250 MCM	M-1337	4	250	B-106	2
	4/0	M-1338	4	200	B-106	2
	2/0	M-1340	4	150	B-106	2
	1/0	M-1341	4	150	B-106	2
	#1	M-1342	4	150	B-106	4
	#2	M-1343	4	150	B-106	2

MOLDS FOR AWG CONDUCTORS						
Cable		Mold #	Price Key	Weld Metal	Handle Clamps	Lead Time
Run	Tap					
300 MCM	300 MCM	M-1344	5	2-150	B-107	2
	250 MCM	M-1345	4	250	B-106	4
	4/0	M-1346	4	200	B-106	2
	2/0	M-1348	4	150	B-106	4
	1/0	M-1349	4	150	B-106	2
	#1	M-1350	4	150	B-106	4
	#2	M-1351	4	150	B-106	4
350 MCM	350 MCM	M-1352	5	2-150	B-107	2
	300 MCM	M-1353	5	2-150	B-107	2
	250 MCM	M-1354	4	250	B-106	4
	4/0	M-1355	4	200	B-106	2
	2/0	M-1357	4	150	B-106	2
	1/0	M-1358	4	150	B-106	4
	#1	M-1359	4	150	B-106	4
500 MCM	#2	M-1360	4	150	B-106	2
	500 MCM	M-1371	5	2-200	B-107	2
	350 MCM	M-1373	5	2-150	B-107	2
	300 MCM	M-1374	5	2-150	B-107	2
	250 MCM	M-1375	4	250	B-106	2
	4/0	M-1376	4	200	B-106	2
	2/0	M-1378	4	150	B-106	2
	1/0	M-1379	4	150	B-106	2
	#1	M-1380	4	150	B-106	4
	#2	M-1381	4	150	B-106	2

- For sizes not listed, contact thermOweld®.
- Molds listed are for concentric stranded cable. Add suffix "-S" to mold number for solid conductors.
- For heavy duty connections, contact thermOweld®.
- For molds with wear plates, see page 135.
- For expedited service, contact thermOweld®.
- To order weld metal for use with EZ Lite Remote® insert TW before and EZ after weld metal number.
- Required Tools;
  - Handle Clamps w/ Flint Ignitor (see chart for correct handles) 38-0309-00 ~ Flint Ignitor or 38-EZLT-RU EZ Lite Remote®
- Other recommended accessories;
  - 40-0319-01 ~ Mold Cleaner for cartridge sizes #15-#65
  - 40-0319-03 ~ Mold Cleaner for cartridge sizes #90-#500
  - 38-3922-00 ~ Mold Cleaning Brush
  - 38-0135-00 ~ Cable Cleaning Brush
  - 38-0330-00 ~ Cable Clamp

## CC-34

### TYPE MOLDS

*Vertical Parallel through Cables  
For AWG Conductors*

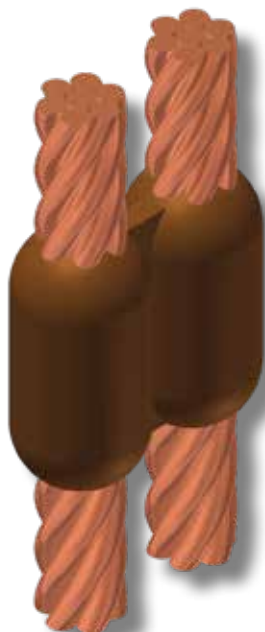

Section 2 - Molds  
AWG Conductors

MOLDS FOR AWG CONDUCTORS						
Cable		Mold #	Price Key	Weld Metal	Handle Clamps	Lead Time
Run	Tap					
#6	#6	M-7379	17	32	B-106	4
#4	#4	M-10500	17	65	B-106	4
	#6	M-10501	17	65	B-106	4
	#6 Sol	M-10502	17	45	B-106	4
#2	#2	M-7304	17	90	B-106	2
	#2 Sol	M-7277	17	90	B-106	2
	#4	M-10503	17	90	B-106	4
#1	#1	M-10504	17	115	B-106	4
	#2	M-10505	17	90	B-106	4
	#2 Sol	M-10506	17	90	B-106	4
	#4	M-10507	17	90	B-106	4
1/0	1/0	M-5	17	150	B-106	2
	#1	M-10508	17	115	B-106	4
	#2	M-10509	17	115	B-106	4
	#2 Sol	M-10510	17	115	B-106	4
	#4	M-10511	17	115	B-106	4
2/0	2/0	M-6494	17	150	B-106	2
	1/0	M-10512	17	150	B-106	4
	#1	M-10513	17	150	B-106	4
	#2	M-10514	17	150	B-106	4
	#2 Sol	M-6683	17	150	B-106	2
4/0	#4	M-10515	17	115	B-106	4
	4/0	M-6596	6	2-200	B-107	2
	2/0	M-7050	17	250	B-106	2
	1/0	M-6716	17	250	B-106	2
	#1	M-10517	17	250	B-106	4
	#2	M-10518	17	200	B-106	4
250 MCM	250 MCM	M-10520	8	500	B-107	4
500 MCM	500 MCM	M-6915	8	3-250	B-107	2

TAP is the cable that is closest to the crucible

RUN is the cable that is farthest from the crucible

- For sizes not listed, contact thermOweld®.
- Molds listed are for concentric stranded cable. Add suffix "-S" to mold number for solid conductors.
- For heavy duty connections, contact thermOweld®.
- For expedited service, contact thermOweld®.
- To order weld metal for use with EZ Lite Remote® insert TW before and EZ after weld metal number.
- Required Tools;
  - Handle Clamps w/ Flint Ignitor (see chart for correct handles)
  - 38-0309-00 ~ Flint Ignitor or 38-EZLT-RU EZ Lite Remote®
- Other recommended accessories;
  - 40-0319-01 ~ Mold Cleaner for cartridge sizes #15-#65
  - 40-0319-03 ~ Mold Cleaner for cartridge sizes #90-#500
  - 38-3922-00 ~ Mold Cleaning Brush
  - 38-0135-00 ~ Cable Cleaning Brush
  - 38-0330-00 ~ Cable Clamp

# CC-11

## TYPE MOLDS

*Horizontal to Horizontal Cable Cross (Uncut)  
For AWG Conductors*

MOLDS FOR AWG CONDUCTORS						
Cable		Mold #	Price Key	Weld Metal	Handle Clamps	Lead Time
Run	Tap					
#6	#6	M-6057	4	45	B-106	2
#4	#4	M-2687	4	65	B-106	2
#2	#2	M-2689	4	90	B-106	2
	#4	M-2690	4	65	B-106	2
#1	#1	M-2691	4	115	B-106	2
	#2	M-2692	4	90	B-106	2
	#4	M-2693	4	90	B-106	4
1/0	1/0	M-2694	22	150	B-106	2
	#1	M-2695	22	150	B-106	2
	#2	M-2696	22	115	B-106	2
	#4	M-2697	22	115	B-106	2
2/0	2/0	M-2698	22	200	B-106	2
	1/0	M-2699	22	200	B-106	2
	#1	M-2700	22	150	B-106	4
3/0	#2	M-2701	22	150	B-106	2
	3/0	M-2702	22	250	B-106	2
	2/0	M-2703	22	200	B-106	4
	1/0	M-2704	22	200	B-106	2
	#1	M-2705	22	150	B-106	2
4/0	#2	M-2706	22	150	B-106	4
	4/0	M-2707	22	250	B-106	SDS
	3/0	M-2708	22	250	B-106	2
	2/0	M-2709	22	200	B-106	2
	1/0	M-2710	22	200	B-106	2
	#1	M-2711	22	150	B-106	4
250 MCM	#2	M-2712	22	150	B-106	2
	250 MCM	M-2713	22	2-150	B-106	2
	4/0	M-2714	22	2-150	B-106	2
	3/0	M-2715	22	2-150	B-106	2
	2/0	M-2716	22	250	B-106	2
	1/0	M-2717	22	150	B-106	2
500 MCM	#1	M-2718	22	200	B-106	4
	#2	M-2719	22	150	B-106	4
	500 MCM	M-2747	23	3-250	B-107	2
	250 MCM	M-2751	23	500	B-107	2
	4/0	M-2752	23	500	B-107	2
	3/0	M-2753	23	500	B-107	2
	2/0	M-2754	23	2-200	B-107	2
	1/0	M-2755	22	2-150	B-106	2
#1	M-2756	22	250	B-106	4	
	#2	M-2757	22	250	B-106	4

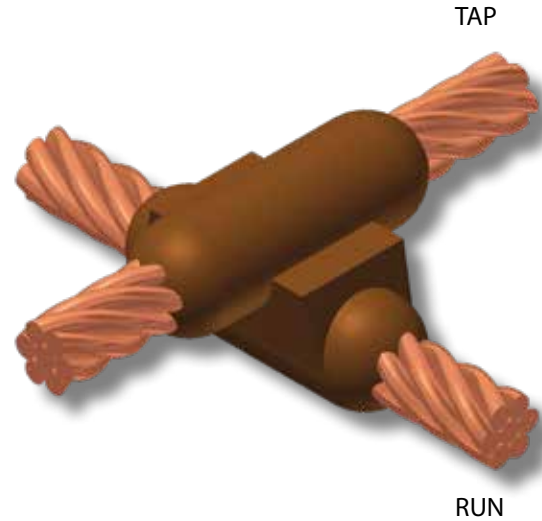

Section 2 - Molds  
AWG Conductors

- For sizes not listed, contact thermOweld®.
- Molds listed are for concentric stranded cable. Add suffix "-S" to mold number for solid conductors.
- For heavy duty connections, contact thermOweld®.
- For molds with wear plates, see page 135.
- For expedited service, contact thermOweld®.
- To order weld metal for use with EZ Lite Remote® insert TW before and EZ after weld metal number.
- Required Tools;
  - Handle Clamps w/ Flint Ignitor (see chart for correct handles)
  - 38-0309-00 ~ Flint Ignitor or 38-EZLT-RU EZ Lite Remote®
- Other recommended accessories;
  - 40-0319-01 ~ Mold Cleaner for cartridge sizes #15-#65
  - 40-0319-03 ~ Mold Cleaner for cartridge sizes #90-#500
  - 38-3922-00 ~ Mold Cleaning Brush
  - 38-0135-00 ~ Cable Cleaning Brush
  - 38-0330-00 ~ Cable Clamp

## CR-1

### TYPE MOLDS

Horizontal Cable Terminal to Ground Rod  
For AWG Conductors

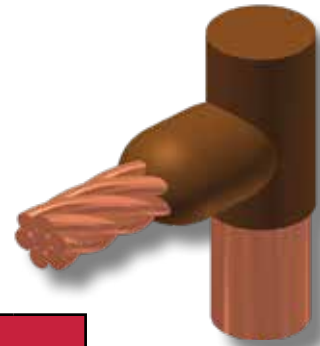

Section 2 - Molds  
AWG Conductors

MOLDS FOR AWG CONDUCTORS											
Ground Rod Size	Cable Size	STANDARD MOLD					HEAVY DUTY CONNECTION				
		Mold #	Price Key	Weld Metal	Handle Clamps	Lead Time	Mold #	Price Key	Weld Metal	Handle Clamps	Lead Time
1/2"	#6	M-5858	4	45	B-106	2	M-5858-H	4	65	B-106	4
	#4	M-6448	4	65	B-106	2	M-6448-H	4	90	B-106	4
	#2	M-495	4	65	B-106	2	M-495-H	4	90	B-106	4
	#1	M-496	4	65	B-106	4	M-496-H	4	90	B-106	4
	1/0	M-497	4	90	B-106	2	M-497-H	4	115	B-106	4
	2/0	M-498	4	90	B-106	2	M-498-H	4	115	B-106	4
	3/0	M-499	4	90	B-106	2	M-499-H	4	150	B-106	4
	4/0	M-500	4	90	B-106	2	M-500-H	4	150	B-106	2
	250 MCM	M-501	4	90	B-106	2	M-501-H	4	150	B-106	4
300 MCM	M-502	4	90	B-106	2	M-502-H	4	150	B-106	4	
5/8"	#6	M-5799	4	45	B-106	2	M-5799-H	4	65	B-106	4
	#4	M-5197	4	65	B-106	2	M-5197-H	4	90	B-106	4
	#2	M-503	4	65	B-106	2	M-503-H	4	90	B-106	2
	#2 Sol	M-503-S	4	65	B-106	2	M-503HS	4	90	B-106	2
	#1	M-504	4	65	B-106	2	M-504-H	4	90	B-106	4
	1/0	M-505	4	90	B-106	2	M-505-H	4	115	B-106	2
	2/0	M-506	4	90	B-106	SDS	M-506-H	4	115	B-106	2
	3/0	M-507	4	90	B-106	2	M-507-H	4	150	B-106	2
	4/0	M-508	4	90	B-106	SDS	M-508-H	4	150	B-106	2
	250 MCM	M-509	4	90	B-106	2	M-509-H	4	150	B-106	4
	300 MCM	M-510	4	115	B-106	2	M-510-H	4	200	B-106	4
350 MCM	M-511	4	115	B-106	2	M-511-H	4	200	B-106	4	
500 MCM	M-513	4	150	B-106	2	M-513-H	4	250	B-106	4	

- For sizes not listed, contact thermOweld®.
- Molds listed are for concentric stranded cable. Add suffix "-S" to mold number for solid conductors.
- Molds listed are for copper clad ground rods. For welding to steel, stainless steel or galvanized steel ground rods add suffix "-N" to mold number.
- For molds with wear plates, see page 135.
- For expedited service, contact thermOweld®.
- To order weld metal for use with EZ Lite Remote® insert TW before and EZ after weld metal number.
- Required Tools;
  - Handle Clamps w/ Flint Ignitor (see chart for correct handles)
  - 38-0309-00 ~ Flint Ignitor or 38-EZLT-RU EZ Lite Remote®
- Other recommended accessories;
  - 40-0319-01 ~ Mold Cleaner for cartridge sizes #15-#65
  - 40-0319-03 ~ Mold Cleaner for cartridge sizes #90-#500
  - 38-3922-00 ~ Mold Cleaning Brush
  - 38-0135-00 ~ Cable Cleaning Brush
  - 38-0330-00 ~ Cable Clamp

#### NOTES

1. Molds listed are for copper clad steel ground rods: 1/2" rods are 0.475" diameter, 5/8" rods are 0.563" diameter, 3/4" rods are 0.682" diameter, and 1" rods are 0.914" diameter. **Undersized ground rods may require shim stock or packing material.**
2. Molds are available for galvanized steel, stainless steel, and solid copper rods that are sold by actual diameter. The suffix "-N" is added to the mold number, i.e. M-XXX-N is for full sized rods.
3. Molds are available for sectional/threaded copper clad steel ground rods. The suffix "-T" is added to the mold number, i.e. M-XXX-T is for a sectional/threaded ground rod.

CR-1

TYPE MOLDS

Horizontal Cable Terminal to Ground Rod For AWG Conductors

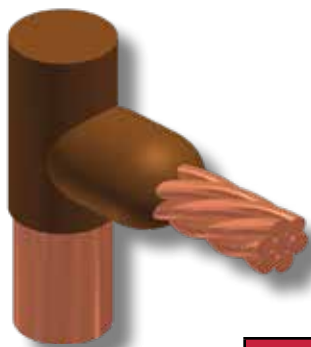

Section 2 - Molds  
AWG Conductors

MOLDS FOR AWG CONDUCTORS											
Ground Rod Size	Cable Size	STANDARD MOLD					HEAVY DUTY CONNECTION				
		Mold #	Price Key	Weld Metal	Handle Clamps	Lead Time	Mold #	Price Key	Weld Metal	Handle Clamps	Lead Time
3/4"	#6	M-5878	4	45	B-106	2	M-5878-H	4	65	B-106	2
	#4	M-5593	4	90	B-106	2	M-5593-H	4	115	B-106	2
	#2	M-5781	4	90	B-106	2	M-5781-H	4	115	B-106	2
	#1	M-514	4	90	B-106	2	M-514-H	4	115	B-106	4
	1/0	M-515	4	90	B-106	2	M-515-H	4	150	B-106	2
	2/0	M-516	4	90	B-106	2	M-516-H	4	150	B-106	2
	3/0	M-517	4	90	B-106	2	M-517-H	4	150	B-106	2
	4/0	M-518	4	90	B-106	SDS	M-518-H	4	150	B-106	2
	250 MCM	M-519	4	90	B-106	2	M-519-H	4	150	B-106	4
	300 MCM	M-520	4	115	B-106	2	M-520-H	4	200	B-106	4
	350 MCM	M-521	4	115	B-106	2	M-521-H	4	200	B-106	4
	500 MCM	M-523	4	150	B-106	2	M-523-H	4	250	B-106	2
	750 MCM	M-524	4	250	B-106	2	M-524-H	5	2-200	B-107	4
	1"	1/0	M-525	4	150	B-106	2	M-525-H	4	200	B-106
2/0		M-526	4	150	B-106	2	M-526-H	4	200	B-106	4
3/0		M-527	4	150	B-106	2	M-527-H	4	250	B-106	4
4/0		M-528	4	150	B-106	2	M-528-H	4	250	B-106	4
250 MCM		M-529	4	150	B-106	2	M-529-H	4	250	B-106	4
300 MCM		M-530	4	200	B-106	4	M-530-H	5	2-150	B-107	4
350 MCM		M-531	4	200	B-106	2	M-531-H	5	2-150	B-107	4
500 MCM		M-533	4	200	B-106	2	M-533-H	5	2-150	B-107	2
750 MCM		M-534	4	250	B-106	4	M-534-H	5	2-200	B-107	4
1000 MCM		M-535	5	2-150	B-107	4	M-535-H	5	500	B-107	4

- For sizes not listed, contact thermOweld®.
- Molds listed are for concentric stranded cable. Add suffix "-S" to mold number for solid conductors.
- Molds listed are for copper clad ground rods. For welding to steel, stainless steel or galvanized steel ground rods add suffix "-N" to mold number.
- For molds with wear plates, see page 135.
- For expedited service, contact thermOweld®.
- To order weld metal for use with EZ Lite Remote® insert TW before and EZ after weld metal number.
- Required Tools;
  - Handle Clamps w/ Flint Ignitor (see chart for correct handles)
  - 38-0309-00 ~ Flint Ignitor or 38-EZLT-RU EZ Lite Remote®
- Other recommended accessories;
  - 40-0319-01 ~ Mold Cleaner for cartridge sizes #15-#65
  - 40-0319-03 ~ Mold Cleaner for cartridge sizes #90-#500
  - 38-3922-00 ~ Mold Cleaning Brush
  - 38-0135-00 ~ Cable Cleaning Brush
  - 38-0330-00 ~ Cable Clamp

NOTES

1. Molds listed are for copper clad steel ground rods: 1/2" rods are 0.475" diameter, 5/8" rods are 0.563" diameter, 3/4" rods are 0.682" diameter, and 1" rods are 0.914" diameter. **Undersized ground rods may require shim stock or packing material.**
2. Molds are available for galvanized steel, stainless steel, and solid copper rods that are sold by actual diameter. The suffix "-N" is added to the mold number, i.e. M-XXX-N is for full sized rods.
3. Molds are available for sectional/threaded copper clad steel ground rods. The suffix "-T" is added to the mold number, i.e. M-XXX-T is for a sectional/threaded ground rod.

## CR-2

### TYPE MOLDS

Horizontal Cable to Ground Rod  
For AWG Conductors

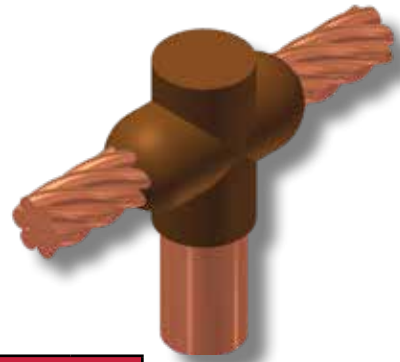

Section 2 - Molds  
AWG Conductors

MOLDS FOR AWG CONDUCTORS											
Ground Rod Size	Cable Size	STANDARD CONNECTION					HEAVY DUTY CONNECTION				
		Mold #	Price Key	Weld Metal	Handle Clamps	Lead Time	Mold #	Price Key	Weld Metal	Handle Clamps	Lead Time
1/2"	#6	M-5786	4	65	B-106	2	M-5786-H	4	90	B-106	4
	#4	M-5388	4	90	B-106	2	M-5388-H	4	150	B-106	4
	#2	M-537	4	90	B-106	2	M-537-H	4	150	B-106	4
	#1	M-538	4	90	B-106	2	M-538-H	4	150	B-106	4
	1/0	M-539	4	90	B-106	2	M-539-H	4	150	B-106	4
	2/0	M-540	4	90	B-106	2	M-540-H	4	150	B-106	2
	3/0	M-541	4	115	B-106	2	M-541-H	4	200	B-106	4
	4/0	M-542	4	115	B-106	2	M-542-H	4	200	B-106	2
5/8"	250 MCM	M-543	4	150	B-106	2	M-543-H	4	250	B-106	4
	300 MCM	M-544	4	200	B-106	4	M-544-H	4	2-150	B-106	4
	#6	M-5815	4	65	B-106	2	M-5815-H	4	115	B-106	4
	#4	M-5915	4	90	B-106	2	M-5915-H	4	150	B-106	4
	#2	M-545	4	90	B-106	SDS	M-545-H	4	150	B-106	2
	#1	M-546	4	90	B-106	2	M-546-H	4	150	B-106	2
	1/0	M-547	4	90	B-106	SDS	M-547-H	4	150	B-106	2
	2/0	M-548	4	115	B-106	SDS	M-548-H	4	200	B-106	2
	3/0	M-549	4	115	B-106	SDS	M-549-H	4	200	B-106	2
	4/0	M-550	4	115	B-106	SDS	M-550-H	4	200	B-106	2
	250 MCM	M-551	4	150	B-106	2	M-551-H	4	250	B-106	4
	300 MCM	M-552	4	200	B-106	2	M-552-H	5	2-150	B-107	4
	350 MCM	M-553	4	200	B-106	2	M-553-H	5	2-150	B-107	4
	500 MCM	M-555	4	250	B-106	2	M-555-H	5	2-200	B-107	2

- For sizes not listed, contact thermOweld®.
- Molds listed are for concentric stranded cable. Add suffix "-S" to mold number for solid conductors.
- Molds listed are for copper clad ground rods. For welding to steel, stainless steel or galvanized steel ground rods add suffix "-N" to mold number.
- For molds with wear plates, see page 135.
- For expedited service, contact thermOweld®.
- To order weld metal for use with EZ Lite Remote® insert TW before and EZ after weld metal number.
- Required Tools;
  - Handle Clamps w/ Flint Ignitor (see chart for correct handles)
  - 38-0309-00 ~ Flint Ignitor or 38-EZLT-RU EZ Lite Remote®
- Other recommended accessories;
  - 40-0319-01 ~ Mold Cleaner for cartridge sizes #15-#65
  - 40-0319-03 ~ Mold Cleaner for cartridge sizes #90-#500
  - 38-3922-00 ~ Mold Cleaning Brush
  - 38-0135-00 ~ Cable Cleaning Brush
  - 38-0330-00 ~ Cable Clamp

NOTES

1. Molds listed are for copper clad steel ground rods: 1/2" rods are 0.475" diameter, 5/8" rods are 0.563" diameter, 3/4" rods are 0.682" diameter, and 1" rods are 0.914" diameter. **Undersized ground rods may require shim stock or packing material.**
2. Molds are available for galvanized steel, stainless steel, and solid copper rods that are sold by actual diameter. The suffix "-N" is added to the mold number, i.e. M-XXX-N is for full sized rods.
3. Molds are available for sectional/threaded copper clad steel ground rods. The suffix "-T" is added to the mold number, i.e. M-XXX-T is for a sectional/threaded ground rod.



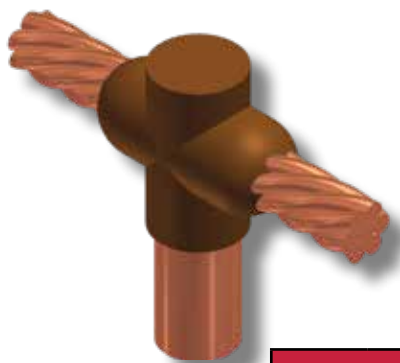

# CR-2

## TYPE MOLDS

Horizontal Cable to Ground Rod  
For AWG Conductors

Section 2 - Molds  
AWG Conductors

MOLDS FOR AWG CONDUCTORS											
Ground Rod Size	Cable Size	STANDARD CONNECTION					HEAVY DUTY CONNECTION				
		Mold #	Price Key	Weld Metal	Handle Clamps	Lead Time	Mold #	Price Key	Weld Metal	Handle Clamps	Lead Time
3/4"	#6	M-5787	4	65	B-106	2	M-5787-H	4	115	B-106	4
	#4	M-6201	4	90	B-106	2	M-6201-H	4	150	B-106	4
	#2	M-556	4	90	B-106	2	M-556-H	4	150	B-106	2
	#1	M-557	4	90	B-106	2	M-557-H	4	150	B-106	4
	1/0	M-558	4	115	B-106	2	M-558-H	4	200	B-106	2
	2/0	M-559	4	115	B-106	SDS	M-559-H	4	200	B-106	2
	3/0	M-560	4	115	B-106	SDS	M-560-H	4	200	B-106	4
	4/0	M-561	4	115	B-106	SDS	M-561-H	4	200	B-106	2
	250 MCM	M-562	4	150	B-106	2	M-562-H	4	250	B-106	2
	300 MCM	M-563	4	200	B-106	2	M-563-H	5	2-150	B-107	4
350 MCM	M-564	4	200	B-106	2	M-564-H	5	2-150	B-107	4	
500 MCM	M-566	4	250	B-106	2	M-566-H	5	2-200	B-107	2	
750 MCM	M-567	5	2-200	B-107	2	M-567-H	5	3-200	B-107	4	
1"	1/0	M-569	4	150	B-106	2	M-569-H	4	250	B-106	4
	2/0	M-570	4	150	B-106	2	M-570-H	4	250	B-106	4
	3/0	M-571	4	150	B-106	2	M-571-H	4	250	B-106	4
	4/0	M-572	4	150	B-106	2	M-572-H	4	250	B-106	2
	250 MCM	M-573	4	200	B-106	2	M-573-H	5	2-150	B-107	4
	300 MCM	M-574	4	200	B-106	4	M-574-H	5	2-150	B-107	4
	350 MCM	M-575	4	200	B-106	2	M-575-H	5	2-150	B-107	4
	500 MCM	M-577	4	250	B-106	2	M-577-H	5	2-200	B-107	4
	750 MCM	M-578	5	2-200	B-107	4	M-578-H	5	3-200	B-107	4
	1000 MCM	M-579	5	500	B-107	4	M-579-H	6	3-250	B-107	2

- For sizes not listed, contact thermOweld®.
- Molds listed are for concentric stranded cable. Add suffix "-S" to mold number for solid conductors.
- Molds listed are for copper clad ground rods. For welding to steel, stainless steel or galvanized steel ground rods add suffix "-N" to mold number.
- For molds with wear plates, see page 135.
- For expedited service, contact thermOweld®.
- To order weld metal for use with EZ Lite Remote® insert TW before and EZ after weld metal number.
- Required Tools;
  - Handle Clamps w/ Flint Ignitor (see chart for correct handles)
  - 38-0309-00 ~ Flint Ignitor or 38-EZLT-RU EZ Lite Remote®
- Other recommended accessories;
  - 40-0319-01 ~ Mold Cleaner for cartridge sizes #15-#65
  - 40-0319-03 ~ Mold Cleaner for cartridge sizes #90-#500
  - 38-3922-00 ~ Mold Cleaning Brush
  - 38-0135-00 ~ Cable Cleaning Brush
  - 38-0330-00 ~ Cable Clamp

- NOTES
1. Molds listed are for copper clad steel ground rods: 1/2" rods are 0.475" diameter, 5/8" rods are 0.563" diameter, 3/4" rods are 0.682" diameter, and 1" rods are 0.914" diameter. **Undersized ground rods may require shim stock or packing material.**
  2. Molds are available for galvanized steel, stainless steel, and solid copper rods that are sold by actual diameter. The suffix "-N" is added to the mold number, i.e. M-XXX-N is for full sized rods.
  3. Molds are available for sectional/threaded copper clad steel ground rods. The suffix "-T" is added to the mold number, i.e. M-XXX-T is for a sectional/threaded ground rod.

## CR-3

### TYPE MOLDS

*Horizontal Thru Cable to Ground Rod  
For AWG Conductors*

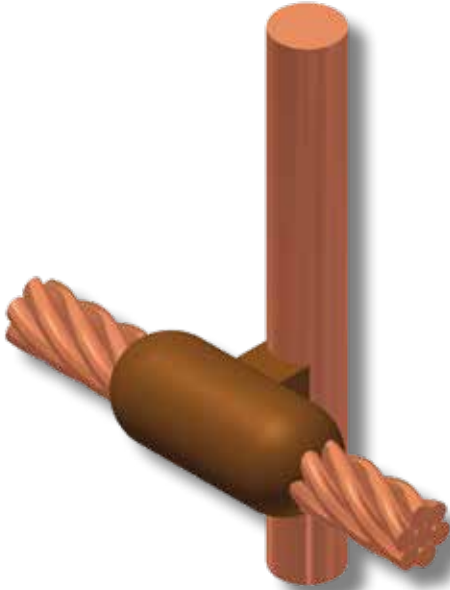

Section 2 - Molds  
AWG Conductors

MOLDS FOR AWG CONDUCTORS							
Ground Rod Size	Cable Size	Mold #	Price Key	Weld Metal	Handle Clamps	Lead Time	
1/2"	#6	M-5321	24	65	B-106	4	
	#4	M-2154	24	90	B-106	2	
	#2	M-2155	24	90	B-106	2	
	#1	M-2156	24	115	B-106	4	
	1/0	M-1581	24	115	B-106	2	
	2/0	M-1582	24	115	B-106	2	
	4/0	M-1583	24	150	B-106	2	
	250 MCM	M-1584	24	150	B-106	4	
5/8"	#6	M-5660	24	65	B-106	2	
	#4	M-2157	24	90	B-106	2	
	#2	M-2158	24	90	B-106	2	
	#1	M-2159	24	115	B-106	2	
	1/0	M-1586	24	115	B-106	2	
	2/0	M-1587	24	115	B-106	SDS	
	4/0	M-1588	24	150	B-106	2	
	250 MCM	M-1589	24	150	B-106	2	
	500 MCM	M-1593	13	2-200	B-107	2	
3/4"	#6	M-6630	24	65	B-106	2	
	#4	M-2160	24	90	B-106	2	
	#2	M-2161	24	90	B-106	2	
	#1	M-2162	24	115	B-106	2	
	1/0	M-1594	24	115	B-106	2	
	2/0	M-1595	24	115	B-106	2	
	4/0	M-1596	24	150	B-106	SDS	
		250 MCM	M-1597	24	200	B-106	2
		500 MCM	M-1601	13	500	B-107	2
	750 MCM	M-1602	13	3-250	B-107	2	
1"	#6	M-6906	24	90	B-106	4	
	#4	M-2163	24	90	B-106	2	
	#2	M-2164	24	90	B-106	2	
	#1	M-2165	24	115	B-106	4	
	1/0	M-1603	24	115	B-106	4	
	2/0	M-1604	24	115	B-106	2	
	4/0	M-1605	24	150	B-106	2	
		250 MCM	M-1606	24	200	B-106	2
		500 MCM	M-1610	13	500	B-107	2
	750 MCM	M-1611	13	3-250	B-107	2	

#### NOTES

- Molds listed are for copper clad steel ground rods: 1/2" rods are 0.475" diameter, 5/8" rods are 0.563" diameter, 3/4" rods are 0.682" diameter, and 1" rods are 0.914" diameter. Undersized ground rods may require shim stock or packing material.
- Molds are available for galvanized steel, stainless steel, and solid copper rods that are sold by actual diameter. The suffix "-N" is added to the mold number, i.e. M-XXX-N is for full sized rods.
- Molds are available for sectional/threaded copper clad steel ground rods. The suffix "-T" is added to the mold number, i.e. M-XXX-T is for a sectional/threaded ground rod.

- **For sizes not listed, contact thermOweld®.**
- Molds listed are for concentric stranded cable. Add suffix "-S" to mold number for solid conductors.
- Molds listed are for copper clad ground rods. For welding to steel, stainless steel or galvanized steel ground rods add suffix "-N" to mold number.
- For heavy duty connections, contact thermOweld®.
- For molds with wear plates, see page 135.
- For expedited service, contact thermOweld®.
- To order weld metal for use with EZ Lite Remote® insert TW before and EZ after weld metal number.
- Required Tools;
  - Handle Clamps w/ Flint Ignitor (see chart for correct handles)
  - 38-0309-00 ~ Flint Ignitor or 38-EZLT-RU EZ Lite Remote®
- Other recommended accessories;
  - 38-3922-00 ~ Mold Cleaning Brush
  - 38-0135-00 ~ Cable Cleaning Brush
  - 38-0304-00 ~ File
  - 38-0330-00 ~ Cable Clamp

# CR-17

## TYPE MOLDS

*Horizontal Run and Tap Cables to Ground Rod For AWG Conductors*

MOLDS FOR AWG CONDUCTORS						
Ground Rod Size	Cable Size	Mold #	Price Key	Weld Metal	Handle Clamps	Lead Time
1/2"	#4	M-5416	4	90	B-106	2
	#2	M-6165	4	90	B-106	2
	#1	M-5830	4	90	B-106	4
	1/0	M-5940	4	115	B-106	2
	2/0	M-5850	4	150	B-106	2
	3/0	M-5833	4	200	B-106	2
	4/0	M-5380	4	200	B-106	2
5/8"	#4	M-5972	4	90	B-106	2
	#2	M-5935	4	115	B-106	2
	#1	M-5699	4	115	B-106	2
	1/0	M-5746	4	150	B-106	2
	2/0	M-5963	4	200	B-106	2
	3/0	M-5734	4	250	B-106	2
	4/0	M-5732	4	250	B-106	2
	250 MCM	M-5722	5	2-150	B-107	2
3/4"	#4	M-5698	4	90	B-106	2
	#2	M-5294	4	115	B-106	2
	#1	M-5390	4	115	B-106	2
	1/0	M-6025	4	150	B-106	2
	2/0	M-5738	4	200	B-106	2
	3/0	M-6003	4	250	B-106	2
	4/0	M-2566	4	250	B-106	2
	250 MCM	M-5904	5	2-150	B-107	2
	300 MCM	M-5857	5	2-200	B-107	4
	350 MCM	M-5777	5	2-200	B-107	2
500 MCM	M-5961	5	3-200	B-107	2	
1"	#4	M-5556	4	115	B-106	4
	#2	M-5555	4	150	B-106	2
	#1	M-6048	4	150	B-106	4
	1/0	M-5992	4	200	B-106	4
	2/0	M-5877	4	250	B-106	4
	3/0	M-5821	5	2-150	B-107	4
	4/0	M-5820	5	2-150	B-107	2
	250 MCM	M-5807	5	2-200	B-107	4
	300 MCM	M-5803	5	500	B-107	4
	350 MCM	M-5561	5	500	B-107	4
	500 MCM	M-5515	6	3-250	B-107	4
750 MCM	M-5513	6	2-500	B-107	4	

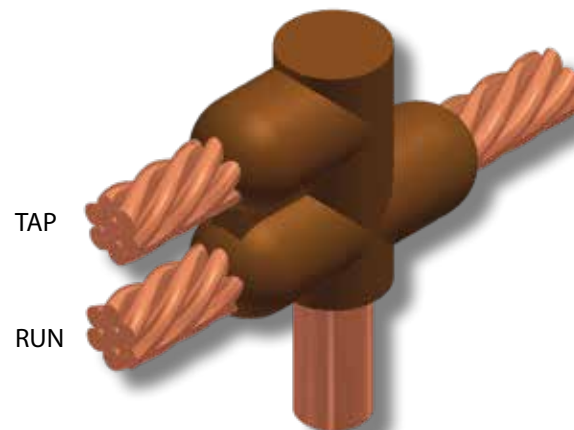

Section 2 - Molds  
AWG Conductors

- For sizes not listed, contact thermOweld®.
- Molds listed are for concentric stranded cable. Add suffix "-S" to mold number for solid conductors.
- Molds listed are for copper clad ground rods. For welding to steel, stainless steel or galvanized steel ground rods add suffix "-N" to mold number.
- For heavy duty connections, contact thermOweld®.
- For expedited service, contact thermOweld®.
- To order weld metal for use with EZ Lite Remote® insert TW before and EZ after weld metal number.
- Required Tools;
  - Handle Clamps w/ Flint Ignitor (see chart for correct handles) 38-0309-00 ~ Flint Ignitor or 38-EZLT-RU EZ Lite Remote®
- Other recommended accessories;
  - 38-3922-00 ~ Mold Cleaning Brush
  - 38-0135-00 ~ Cable Cleaning Brush
  - 38-0304-00 ~ File
  - 38-0330-00 ~ Cable Clamp

NOTES

1. Molds listed are for copper clad steel ground rods: 1/2" rods are 0.475" diameter, 5/8" rods are 0.563" diameter, 3/4" rods are 0.682" diameter, and 1" rods are 0.914" diameter. Undersized ground rods may require shim stock or packing material.
2. Molds are available for galvanized steel, stainless steel, and solid copper rods that are sold by actual diameter. The suffix "-N" is added to the mold number, i.e. M-XXX-N is for full sized rods.
3. Molds are available for sectional/threaded copper clad steel ground rods. The suffix "-T" is added to the mold number, i.e. M-XXX-T is for a sectional/threaded ground rod.

## CR-24

### TYPE MOLDS

*Horizontal Parallel Run Cables to Ground Rod For AWG Conductors*

Section 2 - Molds  
AWG Conductors

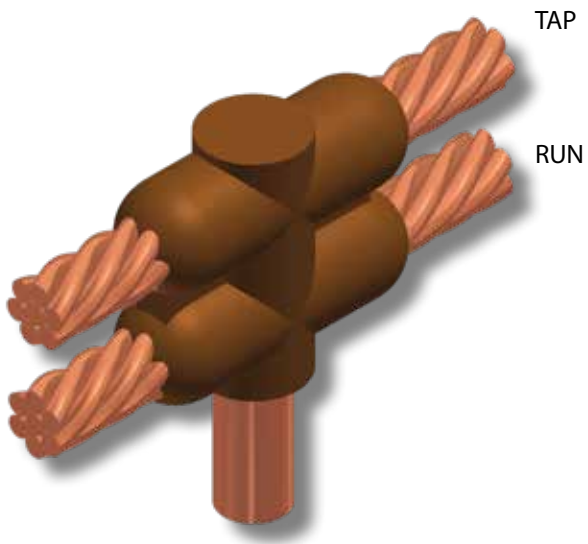

MOLDS FOR AWG CONDUCTORS						
Ground Rod Size	Cable Size	Mold #	Price Key	Weld Metal	Handle Clamps	Lead Time
1/2"	#4	M-5640	4	115	B-106	4
	#2	M-5667	4	115	B-106	2
	#1	M-6002	4	115	B-106	4
	1/0	M-5767	4	150	B-106	2
	2/0	M-5604	4	200	B-106	2
	3/0	M-5560	4	250	B-106	4
5/8"	4/0	M-6766	4	250	B-106	4
	#4	M-6208	4	115	B-106	2
	#2	M-5702	4	150	B-106	2
	#1	M-5517	4	150	B-106	2
	1/0	M-5573	4	200	B-106	2
	2/0	M-8451	4	250	B-106	2
	3/0	M-2510	5	2-150	B-107	2
	4/0	M-5428	5	2-150	B-107	2
	250 MCM	M-1212	5	2-200	B-107	2
	300 MCM	M-2084	5	500	B-107	2
3/4"	350 MCM	M-2558	5	500	B-107	4
	500 MCM	M-2450	5	3-250	B-107	2
	#4	M-8011	4	115	B-106	2
	#2	M-2320	4	150	B-106	2
	#1	M-2235	4	150	B-106	2
	1/0	M-6051	4	200	B-106	2
	2/0	M-8802	4	250	B-106	2
	3/0	M-8726	5	2-150	B-107	2
	4/0	M-5677	5	2-150	B-107	2
	250 MCM	M-8461	5	2-200	B-107	2
1"	300 MCM	M-8428	5	500	B-107	4
	350 MCM	M-8294	5	500	B-107	4
	500 MCM	M-8214	5	3-250	B-107	4
	750 MCM	M-8027	6	2-500	B-107	2
	#4	M-5330	4	150	B-106	4
	#2	M-5332	4	200	B-106	4
	#1	M-5333	4	200	B-106	4
	1/0	M-5334	4	250	B-106	4
	2/0	M-5335	5	2-150	B-107	4
	3/0	M-5336	5	2-200	B-107	4
4/0	M-5337	5	2-200	B-107	2	
250 MCM	M-5338	5	500	B-107	2	
300 MCM	M-5341	5	3-200	B-107	4	
350 MCM	M-5351	5	3-200	B-107	4	
500 MCM	M-5352	6	2-500	B-107	4	

**NOTES**

- Molds listed are for copper clad steel ground rods: 1/2" rods are 0.475" diameter, 5/8" rods are 0.563" diameter, 3/4" rods are 0.682" diameter, and 1" rods are 0.914" diameter. Undersized ground rods may require shim stock or packing material.
- Molds are available for galvanized steel, stainless steel, and solid copper rods that are sold by actual diameter. The suffix "-N" is added to the mold number, i.e. M-XXX-N is for full sized rods.
- Molds are available for sectional/threaded copper clad steel ground rods. The suffix "-T" is added to the mold number, i.e. M-XXX-T is for a sectional/threaded ground rod.

- For sizes not listed, contact thermOweld®.
- Molds listed are for concentric stranded cable. Add suffix "-S" to mold number for solid conductors.
- Molds listed are for copper clad ground rods. For welding to steel, stainless steel or galvanized steel ground rods add suffix "-N" to mold number.
- For heavy duty connections, contact thermOweld®.
- For expedited service, contact thermOweld®.
- To order weld metal for use with EZ Lite Remote® insert TW before and EZ after weld metal number.
- Required Tools;
  - Handle Clamps w/ Flint Ignitor (see chart for correct handles) 38-0309-00 ~ Flint Ignitor or 38-EZLT-RU EZ Lite Remote®
- Other recommended accessories;
  - 38-3922-00 ~ Mold Cleaning Brush
  - 38-0135-00 ~ Cable Cleaning Brush
  - 38-0304-00 ~ File
  - 38-0330-00 ~ Cable Clamp

# CR-18 KITS

## CR-18 WIRE-TO-GROUND KITS

thermOweld® CR-18 Wire-to-Ground Kits are an economical way to make cable connections to a ground rod. The Kit's complete with everything required to make 60 connections. Included in the Starter Kits are (1) Mold complete with handle clamp, (1) spring handle clamp, (60) weld metal cartridges, (1) flint ignitor, (1) mold cleaner, (1) wire brush for cleaning the cable and ground rod, (1) mold cleaning brush and a metal tool box to keep everything in. Refill Kits come complete with (1) replacement mold and (60) weld metal cartridges.



Section 2 - Molds  
AWG Conductors

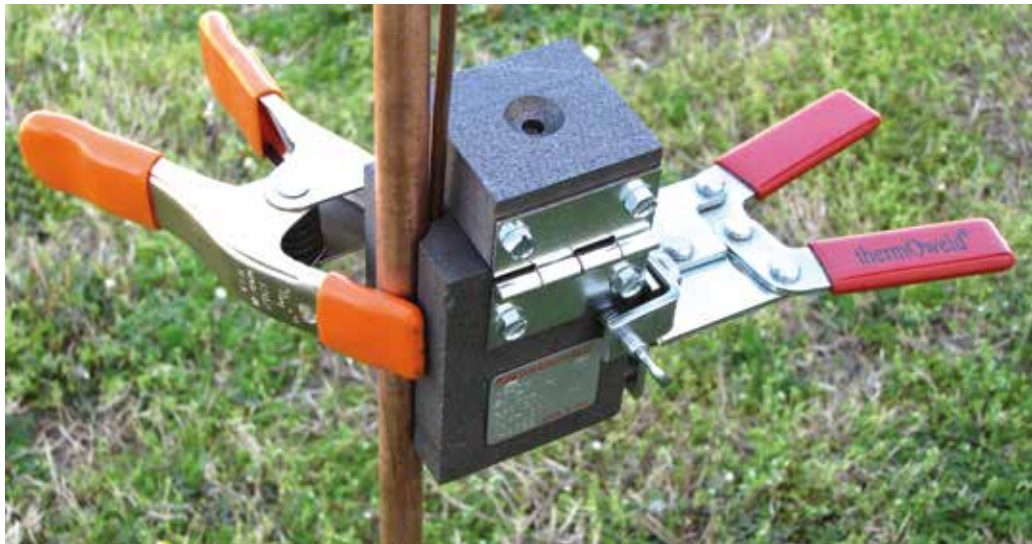

CR-18 WIRE-TO-GROUND KIT			
Kit #	Ground Rod Size	Cable Size	Description
38-6662-01	1/2"	#6 Sol	Starter Kit †
38-6662-11		#6 Sol	Refill Kit with (1) Mold M-10356-GS & (60) #25 weld metal
38-6662-02		#4 Sol	Starter Kit †
38-6662-12	5/8"	#4 Sol	Refill Kit with (1) Mold M-10358-GS & (60) #25 weld metal
38-6662-03		#6 Sol	Starter Kit †
38-6662-13		#6 Sol	Refill Kit with (1) Mold M-10357-GS & (60) #25 weld metal
38-6662-04		#4 Sol	Starter Kit †
38-6662-14	3/4"	#4 Sol	Refill Kit with (1) Mold M-10359-GS & (60) #25 weld metal
38-6662-05		#6 Sol	Starter Kit †
38-6662-15		#6 Sol	Refill Kit with (1) Mold M-10355-GS & (60) #25 weld metal
38-6662-00	3/4"	#4 Sol	Starter Kit †
38-6662-10		#4 Sol	Refill Kit with (1) Mold M-9962-GS & (60) #25 weld metal

† Starter Kits include (1) mold with handle clamp, (1) spring handle clamp, (60) weld metal cartridges, (1) flint ignitor, (1) mold cleaner, (1) wire brush and (1) mold cleaning brush all in a tool box.



# SINGLE SHOT MOLD

## SINGLE SHOT MOLDS

thermOweld® Single Shot Molds are an economical way to make cable connections to the top of a ground rod. The Single Shot is a disposable single use ceramic mold that includes the weld metal and disc. Flint ignitor or EZ Lite Adapter (See page 51) must be purchased separately.

Section 2 - Molds  
AWG Conductors

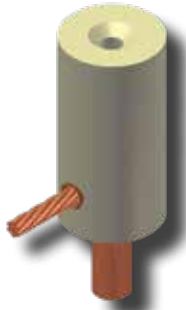

CR-1

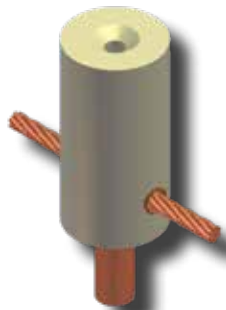

CR-2



CR-24



CR-25

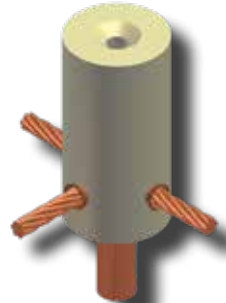
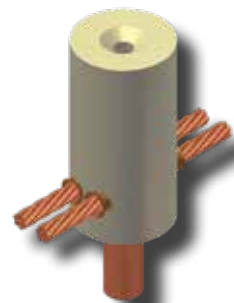

Grd Rod Size	Cable Size		Type	Mold # Std.*	Mold # Remote**	Lead Time
	Solid	Stranded				
1/2"	#6, #8	#8	CR-1	M-2009	M-2009-EZ	4
	#3, #4	#4, #6	CR-1	M-2010	M-2010-EZ	4
	#1, #2	#2, #3	CR-1	M-2011	M-2011-EZ	4
	#6, #8	#8	CR-2	M-2024	M-2024-EZ	4
	#3, #4	#4, #6	CR-2	M-2025	M-2025-EZ	4
	#1, #2	#2, #3	CR-2	M-2026	M-2026-EZ	4

Grd Rod Size	Cable Size		Type	Mold # Std.*	Mold # Remote**	Lead Time
	Solid	Stranded				
5/8"	#6, #8	#8	CR-1	M-2012	M-2012-EZ	SDS
	#3, #4	#4, #6	CR-1	M-2013	M-2013-EZ	SDS
	#1, #2	#2, #3	CR-1	M-2014	M-2014-EZ	SDS
	2/0, 1/0	1/0, #1	CR-1	M-2015	M-2015-EZ	SDS
			CR-1	M-2016	M-2016-EZ	4
	#6, #8	#8	CR-2	M-2027	M-2027-EZ	SDS
	#3, #4	#4, #6	CR-2	M-2028	M-2028-EZ	4
	#1, #2	#2, #3	CR-2	M-2029	M-2029-EZ	SDS
	2/0, 1/0	1/0, #1	CR-2	M-2030	M-2030-EZ	4
			CR-24	M-2105	M-2105-EZ	4
	#3, #4	#4, #6	CR-24	M-2106	M-2106-EZ	4
	#1, #2	#2, #3	CR-24	M-2107	M-2107-EZ	SDS
	#6, #8	#8	CR-25	M-2006	M-2006-EZ	SDS
	#3, #4	#4, #6	CR-25	M-2007	M-2007-EZ	4
	#1, #2	#2, #3	CR-25	M-2008	M-2008-EZ	SDS

Grd Rod Size	Cable Size		Type	Mold # Std.*	Mold # Remote**	Lead Time
	Solid	Stranded				
3/4"	#6, #8	#8	CR-1	M-2017	M-2017-EZ	SDS
	#3, #4	#4, #6	CR-1	M-2018	M-2018-EZ	SDS
	#1, #2	#2, #3	CR-1	M-2019	M-2019-EZ	4
	2/0, 1/0	1/0, #1	CR-1	M-2020	M-2020-EZ	4
			CR-1	M-2021	M-2021-EZ	SDS
	#6, #8	#8	CR-2	M-2031	M-2031-EZ	4
	#3, #4	#4, #6	CR-2	M-2032	M-2032-EZ	SDS
	#1, #2	#2, #3	CR-2	M-2033	M-2033-EZ	4
	2/0, 1/0	1/0, #1	CR-2	M-2034	M-2034-EZ	4
			CR-24	M-2108	M-2108-EZ	4
	#3, #4	#4, #6	CR-24	M-2109	M-2109-EZ	4
	#1, #2	#2, #3	CR-24	M-2110	M-2110-EZ	4
	#6, #8	#8	CR-25	M-2068	M-2068-EZ	4
	#3, #4	#4, #6	CR-25	M-2069	M-2069-EZ	4
	#1, #2	#2, #3	CR-25	M-2070	M-2070-EZ	4

\* Standard ignition

\*\*EZ Lite Remote® ignition, Battery Unit and Adapter sold separately.



# SINGLE SHOT MOLD

## EZ Lite Remote® Adapter

Follow steps 1 thru 10 in the Welding Instructions "Weld Procedures" that comes with the Single Shot Mold for proper installation of mold onto ground rod and how to place weld metal into mold.

Replace step 11 in the Welding Instructions "Weld Procedures" with the following;

11. Discard ceramic lid included with mold. Slide EZ Lite Remote® Single Shot Adapter over mold as shown.

Continue the instructions steps 12 through 14 in the Welding Instructions "Weld Procedures" that comes with the Single Shot Mold to complete weld.

Part Number: 38-EZLT-SS

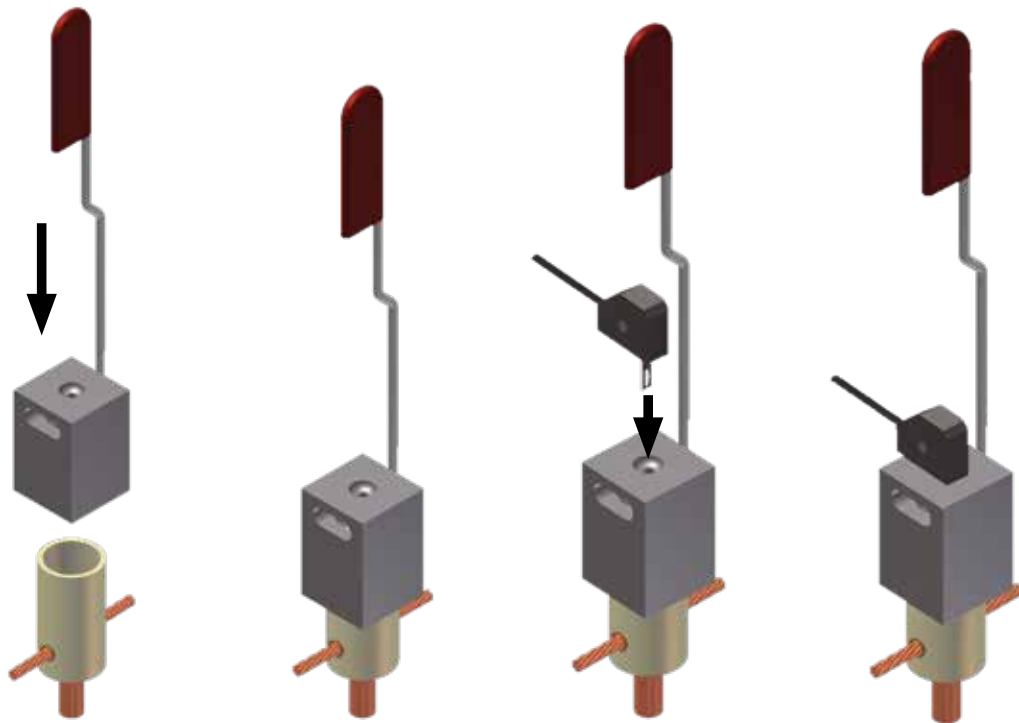

## RR-1

### TYPE MOLDS

Ground Rod to Ground Rod



Ground Rod Size	Mold #	Price Key	Weld Metal	Handle Clamps	Lead Time
1/2"	M-581-H	4	250	B-106	2
5/8"	M-582-H	5	2-150	B-107	2
3/4"	M-583-H	5	2-200	B-107	2
1"	M-584-H	6	3-250	B-107	2

- For sizes not listed, contact thermOweld®.
- Molds listed are for copper clad ground rods. For welding to steel, stainless steel or galvanized steel ground rods add suffix "-N" to mold number.
- For expedited service, contact thermOweld®.
- To order weld metal for use with EZ Lite Remote® insert TW before and EZ after weld metal number.
- Required Tools;
  - Handle Clamps w/ Flint Ignitor (see chart for correct handles)
  - 38-0309-00 ~ Flint Ignitor or 38-EZLT-RU EZ Lite Remote®
- Other recommended accessories;
  - 38-3922-00 ~ Mold Cleaning Brush
  - 38-0304-00 ~ File

NOTES

1. .475" actual diameter. For full 1/2" (.500) ground rod and roll-threaded rod, add suffix "-N" to mold number, i.e. M-581-HN is full 1/2" diameter ground rod or roll-threaded rod to 4/0 Str cable. **Undersized ground rods may require shim stock or packing material.**
2. .563" actual diameter. For full 5/8" (.625) ground rod and roll-threaded rod, add suffix "-N" to mold number, i.e. M-582-HN is full 5/8" diameter ground rod or roll-threaded rod to 4/0 Str cable.
3. .682" actual diameter. For full 3/4" (.750) ground rod and roll-threaded rod, add suffix "-N" to mold number, i.e. M-583-HN is full 3/4" diameter ground rod or roll-threaded rod to 4/0 Str. cable.
4. .914" actual diameter. For full 1" (1.00) ground rod and roll-threaded rod, add suffix "-N" to mold number, i.e. M-584-HN is full 1" diameter ground rod or roll-threaded rod to 4/0 Str. cable.

Section 2 - Molds  
AWG Conductors

## RS-1/RS-2

### TYPE MOLDS

Horizontal and Vertical Stud to Steel

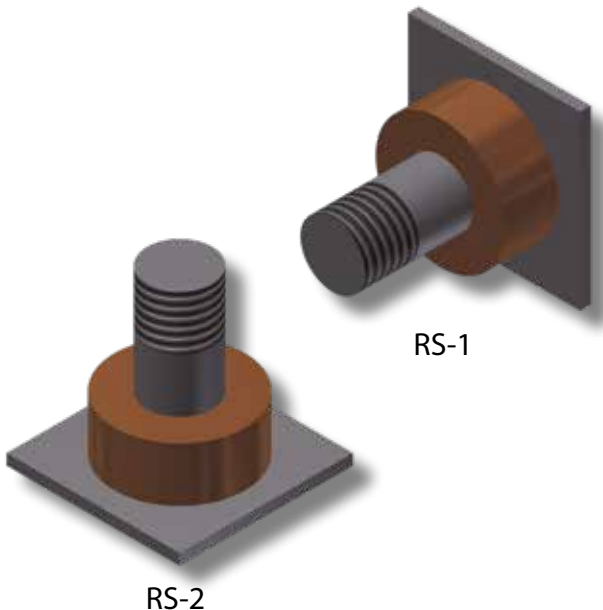

Stud Size	Type RS-1	Type RS-2	Price Key	Weld Metal	Handle Clamps	Lead Time
1/4"	M-1880	M-1886	4	25	B-106	2
5/16"	M-1881	M-1887	4	25	B-106	4
3/8"	M-1882	M-1888	4	45	B-106	2
1/2"	M-1883	M-1889	4	65	B-106	2
3/4"	M-1884	M-1890	4	150	B-106	2
1"	M-1885	M-1891	4	250	B-106	2

- For sizes not listed, contact thermOweld®.
- For heavy duty connections, contact thermOweld®.
- Molds for copper studs available, contact thermOweld®.
- For expedited service, contact thermOweld®.
- To order weld metal for use with EZ Lite Remote® insert TW before and EZ after weld metal number.
- Required Tools;
  - Handle Clamps w/ Flint Ignitor (see chart for correct handles)
  - 38-0309-00 ~ Flint Ignitor or 38-EZLT-RU EZ Lite Remote®
- Other recommended accessories;
  - 38-3922-00 ~ Mold Cleaning Brush
  - 38-0101-00 ~ Rasp

# CS-1

## TYPE MOLDS

*Horizontal Cable to Horizontal Steel Surface  
For AWG Conductors*

Note that the cable is **OFF** the surface

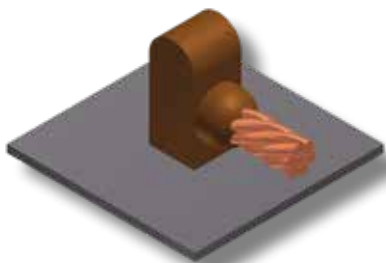

MOLDS FOR AWG CONDUCTORS										
Cable Size	STANDARD CONNECTION					HEAVY DUTY CONNECTION				
	Mold #	Price Key	Weld Metal	Handle Clamps	Lead Time	Mold #	Price Key	Weld Metal	Handle Clamps	Lead Time
1/0	M-644	4	90	B-106	2	M-644-H	4	150	B-106	2
2/0	M-645	4	90	B-106	2	M-645-H	4	150	B-106	2
3/0	M-646	4	115	B-106	2	M-646-H	4	200	B-106	2
4/0	M-647	4	115	B-106	SDS	M-647-H	4	200	B-106	2
250 MCM	M-648	4	115	B-106	2	M-648-H	4	200	B-106	2
300 MCM	M-649	4	150	B-106	2	M-649-H	4	250	B-106	2
350 MCM	M-650	4	200	B-106	2	M-650-H	5	2-150	B-107	4
500 MCM	M-652	4	200	B-106	2	M-652-H	5	2-150	B-107	2
750 MCM	M-653	5	2-150	B-107	2	M-653-H	5	500	B-107	4
1000 MCM	M-654	5	2-200	B-107	4	M-654-H	5	3-200	B-107	4

Section 2 - Molds  
AWG Conductors

MOLDS FOR AWG CONDUCTORS					
Cable Size	Mold #	Price Key	Weld Metal	Handle Clamps	Lead Time
#6	M-628	3†	45	Included	2
#4	M-629	3†	45	Included	2
#2	M-630	3†	45	Included	2
#2	M-630-S	3†	45	Included	SDS
#1	M-631	3†	65	Included	2
1/0	M-7146	4	90	B-106	2
2/0	M-7075	4	90	B-106	2
3/0	M-2199	4	115	B-106	2
4/0	M-6114	4	115	B-106	2
250 MCM	M-2200	4	115	B-106	2
300 MCM	M-2506	4	150	B-106	2
350 MCM	M-2507	4	200	B-106	2
500 MCM	M-2509	4	200	B-106	2
750 MCM	M-2542	5	2-150	B-107	2
1000 MCM	M-2511	5	2-200	B-107	4

# CS-8

## TYPE MOLDS

*Horizontal Cable to Horizontal Steel Surface  
For AWG Conductors.*

Note that the cable is **ON** the surface



- **For sizes not listed, contact thermOweld®.**
- Molds listed are for concentric stranded cable. Add suffix "-S" to mold number for solid conductors.
- For molds with wear plates, see page 135.
- For expedited service, contact thermOweld®.
- To order weld metal for use with EZ Lite Remote® insert TW before and EZ after weld metal number.
- Required Tools;
  - Handle Clamps w/ Flint Ignitor (see chart for correct handles)
  - † ~ Sold complete with frame
  - 38-0309-00 ~ Flint Ignitor or 38-EZLT-RU EZ Lite Remote®
- Other recommended accessories;
  - 40-0319-01 ~ Mold Cleaner for cartridge sizes #15-#65 (Price Key 3, CS-8 Molds Only)
  - 38-3922-00 ~ Mold Cleaning Brush
  - 38-0135-00 ~ Cable Cleaning Brush
  - 38-0101-00 ~ Rasp
  - 38-4129-00 ~ Packing Material for 1/0 & Larger Molds (CS-8 Molds Only)

**Welding to Horizontal Pipe:** To weld to horizontal pipe, add pipe size to mold number. Example: To weld 4/0 str cable to 6" horizontal pipe, the mold number would be M-647-6. To weld #1 cable or smaller to pipe 14" and larger, use flat surface mold. For 1/0 cable and larger, use flat surface mold only on pipe 30" and larger.

## CS-2

### TYPE MOLDS

**Horizontal Thru Cable to Horizontal Steel Surface  
For AWG Conductors**

Note that the cable is **OFF** the surface

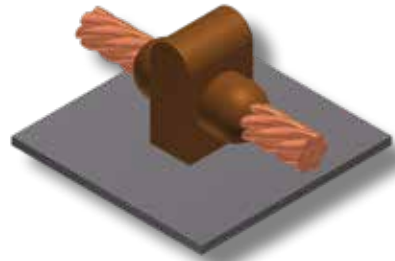

Section 2 - Molds  
AWG Conductors

MOLDS FOR AWG CONDUCTORS										
Cable Size	STANDARD CONNECTION					HEAVY DUTY CONNECTION				
	Mold #	Price Key	Weld Metal	Handle Clamps	Lead Time	Mold #	Price Key	Weld Metal	Handle Clamps	Lead Time
1/0	M-616	4	90	B-106	2	M-616-H	4	150	B-106	4
2/0	M-617	4	115	B-106	2	M-617-H	4	200	B-106	4
3/0	M-618	4	115	B-106	2	M-618-H	4	200	B-106	4
4/0	M-619	4	150	B-106	2	M-619-H	4	250	B-106	2
250 MCM	M-620	4	150	B-106	2	M-620-H	4	250	B-106	4
300 MCM	M-621	4	200	B-106	2	M-621-H	5	2-150	B-107	4
350 MCM	M-622	4	250	B-106	4	M-622-H	5	2-200	B-107	4
500 MCM	M-624	5	2-150	B-107	2	M-624-H	5	500	B-107	4
750 MCM	Use Heavy Duty Connection					M-625-H	5	3-250	B-107	4
1000 MCM						M-626-H	5	2-500	B-107	4

## CS-9

### TYPE MOLDS

**Horizontal Thru Cable to Horizontal Steel Surface  
For AWG Conductors**

Note that the cable is **ON** the surface

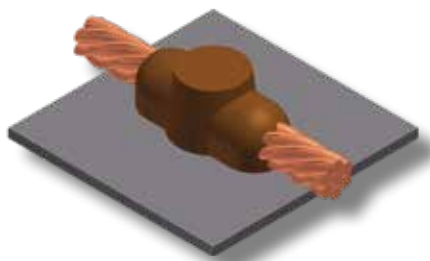

MOLDS FOR AWG CONDUCTORS					
Cable Size	Mold #	Price Key	Weld Metal	Handle Clamps	Lead Time
#6	M-602	3†	45	Included	2
#4	M-603	3†	45	Included	2
#2	M-604	3†	45	Included	2
#1	M-605	3†	65	Included	4
1/0	M-8379	4	90	B-106	2
2/0	M-5331	4	115	B-106	2
3/0	M-8381	4	115	B-106	2
4/0	M-7192	4	150	B-106	2
250 MCM	M-8413	4	150	B-106	2
300 MCM	M-8423	4	200	B-106	4
350 MCM	M-8410	4	250	B-106	4
500 MCM	M-5065	5	2-150	B-107	2

- For sizes not listed, contact thermOweld®.
- Molds listed are for concentric stranded cable. Add suffix "-S" to mold number for solid conductors.
- For molds with wear plates, see page 135.
- For expedited service, contact thermOweld®.
- To order weld metal for use with EZ Lite Remote® insert TW before and EZ after weld metal number.
- Required Tools;
  - Handle Clamps w/ Flint Ignitor (see chart for correct handles)
  - † ~ Sold complete with frame
  - 38-0309-00 ~ Flint Ignitor or 38-EZLT-RU EZ Lite Remote®
- Other recommended accessories;
  - 40-0319-01 ~ Mold Cleaner for cartridge sizes #15-#65 (Price Key 3, CS-9 Molds Only)
  - 38-3922-00 ~ Mold Cleaning Brush
  - 38-0135-00 ~ Cable Cleaning Brush
  - 38-0101-00 ~ Rasp
  - 38-4129-00 ~ Packing Material for 1/0 & Larger Molds (CS-9 Molds Only)

**Welding to Horizontal Pipe:** To weld to horizontal pipe, add pipe size to mold number. Example: To weld 4/0 str cable to 6" horizontal pipe, the mold number would be M-619-6. To weld #1 cable or smaller to pipe 14" and larger, use flat surface mold. For 1/0 cable and larger, use flat surface mold only on pipe 30" and larger.

**CS-3**

**TYPE MOLDS**

*Angular Cable Drop to Vertical Steel Surface  
For AWG Conductors*

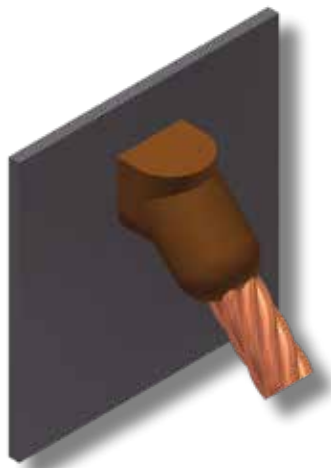

MOLDS FOR AWG CONDUCTORS										
Cable Size	STANDARD CONNECTION					HEAVY DUTY CONNECTION				
	Mold #	Price Key	Weld Metal	Handle Clamps	Lead Time	Mold #	Price Key	Weld Metal	Handle Clamps	Lead Time
#6	M-585	4	45	B-106	2	M-585-H	4	65	B-106	2
#4	M-586	4	45	B-106	2	M-586-H	4	65	B-106	2
#2	M-588	4	45	B-106	SDS	M-588-H	4	90	B-106	2
#1	M-589	4	65	B-106	2	M-589-H	4	115	B-106	2
1/0	M-590	4	90	B-106	SDS	M-590-H	4	150	B-106	2
2/0	M-591	4	90	B-106	SDS	M-591-H	4	150	B-106	2
3/0	M-592	4	115	B-106	2	M-592-H	4	200	B-106	4
4/0	M-593	4	115	B-106	SDS	M-593-H	4	200	B-106	2
250 MCM	M-594	4	115	B-106	2	M-594-H	4	200	B-106	2
300 MCM	M-595	4	150	B-106	2	M-595-H	4	250	B-106	4
350 MCM	M-596	4	200	B-106	2	M-596-H	4	250	B-106	4
500 MCM	M-598	4	200	B-106	2	M-598-H	5	2-150	B-107	2
750 MCM	M-599	5	2-150	B-107	2	M-599-H	5	500	B-107	4
1000 MCM	M-600	5	2-200	B-107	2	M-600-H	5	3-200	B-107	4

- For sizes not listed, contact thermOweld®.
- Molds listed are for concentric stranded cable. Add suffix "-S" to mold number for solid conductors.
- For molds with wear plates, see page 135.
- For expedited service, contact thermOweld®.
- To order weld metal for use with EZ Lite Remote® insert TW before and EZ after weld metal number.
- Required Tools;
  - Handle Clamps w/ Flint Ignitor (see chart for correct handles)
  - 38-0309-00 ~ Flint Ignitor or 38-EZLT-RU EZ Lite Remote®
- Other recommended accessories;
  - 40-0106-32 ~ Vertical Chain Clamp w/ B-106 Handles
  - 40-0107-32 ~ Vertical Chain Clamp w/ B-107 Handles
  - 40-4431-00 ~ Magnetic Handle Clamp w/ B-106 Handles
  - 38-3922-00 ~ Mold Cleaning Brush
  - 38-0135-00 ~ Cable Cleaning Brush
  - 38-0101-00 ~ Rasp

## CS-3

### TYPE MOLDS

Angular Cable Drop to Vertical Steel Pipe  
For AWG Conductors

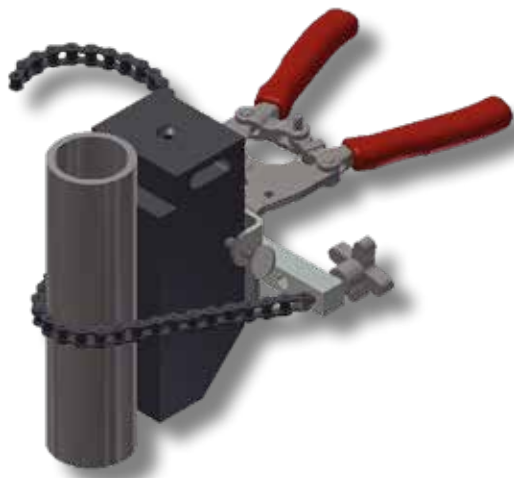

Use 40-0106-32 Vertical Chain Clamps to help hold mold to pipe

Section 2 - Molds  
AWG Conductors

**MOLDS FOR AWG CONDUCTORS**

Cable Size	Pipe Size	Mold #	Price Key	Weld Metal	Handle Clamps	Lead Time
#4	1 1/4" to 4"	M-2476	4	45	B-106	2
	4" to 6"	M-2477	4	45	B-106	2
	6" to 10"	M-2478	4	45	B-106	2
	12" & up	M-586 ‡	4	45	B-106	2
#2 Sol	1 1/4" to 4"	M-9233-S	4	45	B-106	SDS
	4" to 6"	M-2480-S	4	45	B-106	2
	6" to 10"	M-2583-S	4	45	B-106	2
	12" & up	M-588-S ‡	4	45	B-106	SDS
#2	1 1/4" to 4"	M-9233	4	45	B-106	SDS
	4" to 6"	M-2480	4	45	B-106	2
	6" to 10"	M-2583	4	45	B-106	2
	12" & up	M-588 ‡	4	45	B-106	SDS
#1	1 1/4" to 4"	M-2482	4	65	B-106	2
	4" to 6"	M-2483	4	65	B-106	2
	6" to 10"	M-2484	4	65	B-106	2
	12" & up	M-589 ‡	4	65	B-106	2
1/0	1 1/4" to 4"	M-2486	4	90	B-106	2
	4" to 6"	M-2487	4	90	B-106	2
	6" to 10"	M-2488	4	90	B-106	2
	12" & up	M-590 ‡	4	90	B-106	SDS
2/0	1 1/4" to 4"	M-8833	4	90	B-106	SDS
	4" to 6"	M-2490	4	90	B-106	2
	6" to 10"	M-2491	4	90	B-106	2
	12" & up	M-591 ‡	4	90	B-106	SDS
3/0	1 1/4" to 4"	M-2493	4	115	B-106	2
	4" to 6"	M-2494	4	115	B-106	2
	6" to 10"	M-2495	4	115	B-106	2
	12" & up	M-592 ‡	4	115	B-106	2
4/0	1 1/4" to 4"	M-9021	4	115	B-106	SDS
	4" to 6"	M-2497	4	115	B-106	2
	6" to 10"	M-2498	4	115	B-106	2
	12" & up	M-593 ‡	4	115	B-106	SDS

- For sizes not listed, contact thermOweld®.
  - Molds listed are for concentric stranded cable. Add suffix "-S" to mold number for solid conductors.
  - For molds with wear plates, see page 135.
  - For expedited service, contact thermOweld®.
  - To order weld metal for use with EZ Lite Remote® insert TW before and EZ after weld metal number.
  - Required Tools;
    - Handle Clamps w/ Flint Ignitor (see chart for correct handles) 38-0309-00 ~ Flint Ignitor or 38-EZLT-RU EZ Lite Remote®
  - Other recommended accessories;
    - 40-0106-32 ~ Vertical Chain Clamp w/ B-106 Handles for 4" Pipe & smaller
    - 40-0106-27 ~ 20" Chain Extension for 4" to 10" Pipe
    - Use (2) 20" Chain Extensions for pipe sizes between 10" and 16"
    - 40-4431-00 ~ Magnetic Handle Clamp w/ B-106 Handles
    - 38-3922-00 ~ Mold Cleaning Brush
    - 38-0135-00 ~ Cable Cleaning Brush
    - 38-0101-00 ~ Rasp
- ‡ Flat Surface Mold



CS-23

TYPE MOLDS

Vertical Cable Drop to Vertical Steel Surface  
For AWG Conductors

Note that the cable is **OFF** the surface

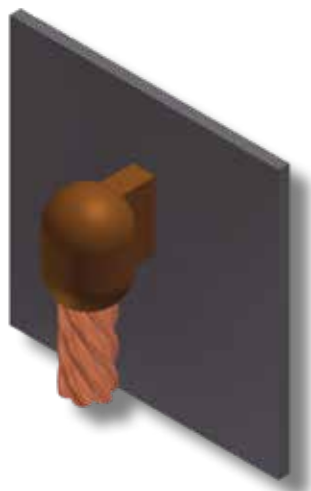

Section 2 - Molds  
AWG Conductors

MOLDS FOR AWG CONDUCTORS										
Cable Size	STANDARD CONNECTION					HEAVY DUTY CONNECTION				
	Mold #	Price Key	Weld Metal	Handle Clamps	Lead Time	Mold #	Price Key	Weld Metal	Handle Clamps	Lead Time
#6	M-5389	4	45	B-106	2	M-5389-H	4	90	B-106	4
#4	M-5359	4	65	B-106	2	M-5359-H	4	115	B-106	2
#2	M-2781	4	65	B-106	2	M-2781-H	4	115	B-106	2
#2 Sol	M-2781-S	4	65	B-106	SDS	M-2781-HS	4	115	B-106	2
#1	M-5361	4	90	B-106	4	M-5361-H	4	150	B-106	4
1/0	M-2189	4	115	B-106	2	M-2189-H	4	200	B-106	2
2/0	M-2540	4	115	B-106	SDS	M-2540-H	4	200	B-106	2
3/0	M-5362	4	150	B-106	2	M-5362-H	4	250	B-106	2
4/0	M-8718	4	150	B-106	SDS	M-8718-H	4	250	B-106	2
250 MCM	M-8165	4	200	B-106	2	M-8165-H	17	2-150	B-106	4
300 MCM	M-5363	4	200	B-106	2	M-5363-H	17	2-150	B-106	2
350 MCM	M-9029	4	250	B-106	2	M-9029-H	5	2-200	B-107	4
500 MCM	M-8512	17	2-150	B-106	2	M-8512-H	6	500	B-107	2

- For sizes not listed, contact thermOweld®.
- Molds listed are for concentric stranded cable. Add suffix "-S" to mold number for solid conductors.
- For expedited service, contact thermOweld®.
- To order weld metal for use with EZ Lite Remote® insert TW before and EZ after weld metal number.
- Required Tools;
  - Handle Clamps w/ Flint Ignitor (see chart for correct handles)  
38-0309-00 ~ Flint Ignitor or 38-EZLT-RU EZ Lite Remote®
- Other recommended accessories;
  - 40-0106-32 ~ Vertical Chain Clamp w/ B-106 Handles for 4" Pipe & smaller
  - 40-0106-27 ~ 20" Chain Extension for 4" to 10" Pipe  
Use (2) 20" Chain Extensions for pipe sizes between 10" and 16"
  - 40-4431-00 ~ Magnetic Handle Clamp w/ B-106 Handles
  - 38-3922-00 ~ Mold Cleaning Brush
  - 38-0135-00 ~ Cable Cleaning Brush
  - 38-0101-00 ~ Rasp

## CS-23

### TYPE MOLDS

#### Vertical Cable Drop to Vertical Steel Pipe

#### For AWG Conductors

Note that the cable is **OFF** the surface

Section 2 - Molds  
AWG Conductors

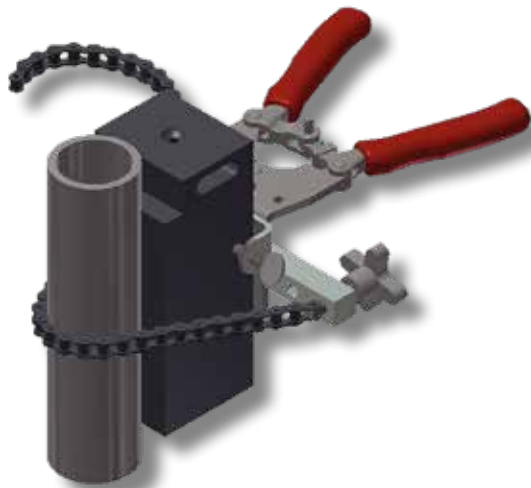
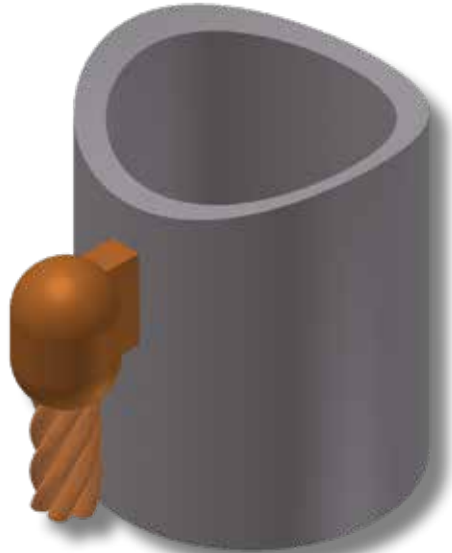

Use 40-0106-32 Vertical Chain Clamps to help hold mold to pipe

MOLDS FOR AWG CONDUCTORS						
Cable Size	Pipe Size	Mold #	Price Key	Weld Metal	Handle Clamps	Lead Time
#4	1 1/4" to 4"	M-8591	4	65	B-106	2
	4" to 6"	M-10521	4	65	B-106	4
	6" to 10"	M-10523	4	65	B-106	4
	12" & up	M-10524 ‡	4	65	B-106	4
#2 Sol	1 1/4" to 4"	M-6199-S	4	65	B-106	SDS
	4" to 6"	M-10528-S	4	65	B-106	4
	6" to 10"	M-10529-S	4	65	B-106	4
	12" & up	M-10530-S ‡	4	65	B-106	4
#2	1 1/4" to 4"	M-6199	4	65	B-106	4
	4" to 6"	M-10528	4	65	B-106	4
	6" to 10"	M-10529	4	65	B-106	2
	12" & up	M-10530 ‡	4	65	B-106	2
#1	1 1/4" to 4"	M-10531	4	90	B-106	2
	4" to 6"	M-10532	4	90	B-106	4
	6" to 10"	M-10533	4	90	B-106	4
	12" & up	M-10534 ‡	4	90	B-106	4
1/0	1 1/4" to 4"	M-10535	4	115	B-106	2
	4" to 6"	M-1147	4	115	B-106	4
	6" to 10"	M-10536	4	115	B-106	2
	12" & up	M-10537 ‡	4	115	B-106	4
2/0	1 1/4" to 4"	M-10538	4	115	B-106	2
	4" to 6"	M-10539	4	115	B-106	4
	6" to 10"	M-10540	4	115	B-106	4
	12" & up	M-10541 ‡	4	115	B-106	4
4/0	1 1/4" to 4"	M-5622	4	150	B-106	2
	4" to 6"	M-7381	4	150	B-106	2
	6" to 10"	M-10365	4	150	B-106	2
	12" & up	M-10542 ‡	4	150	B-106	4

- For sizes not listed, contact thermOweld®.
  - Molds listed are for concentric stranded cable. Add suffix "-S" to mold number for solid conductors.
  - For expedited service, contact thermOweld®.
  - To order weld metal for use with EZ Lite Remote® insert TW before and EZ after weld metal number.
  - Required Tools;
    - Handle Clamps w/ Flint Ignitor (see chart for correct handles) 38-0309-00 ~ Flint Ignitor or 38-EZLT-RU EZ Lite Remote®
  - Other recommended accessories;
    - 40-0106-32 ~ Vertical Chain Clamp w/ B-106 Handles for 4" Pipe & smaller
    - 40-0106-27 ~ 20" Chain Extension for 4" to 10" Pipe
    - Use (2) 20" Chain Extensions for pipe sizes between 10" and 16"
    - 40-4431-00 ~ Magnetic Handle Clamp w/ B-106 Handles
    - 38-3922-00 ~ Mold Cleaning Brush
    - 38-0135-00 ~ Cable Cleaning Brush
    - 38-0101-00 ~ Rasp
- ‡ Flat Surface Mold

# CS-5

## TYPE MOLDS

### Horizontal Cable Tap to Horizontal Cast Iron Surface

#### For AWG Conductors

Note that the cable is **ON** the surface

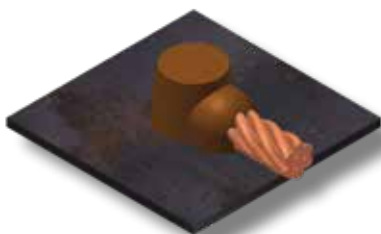

**DO NOT** use Type CS-5 molds on Soil Pipe (ASTM A74-82). A test weld should be made on a section of the pipe being used to determine the possibility of detrimental metallurgical effects.

**Welding to Horizontal Pipe:** To weld to horizontal cast iron pipe, add pipe size to mold number. Example: To weld #1 STR cable to 6" horizontal cast iron pipe, the mold number would be M-1620-6. To weld #1 cable or smaller to pipe 14" and larger, use flat surface mold.

MOLDS FOR AWG CONDUCTORS					
Cable Size	Mold #	Price Key	Weld Metal	Handle Clamps	Lead Time
#6 Sol	M-1613	3†	25Cl	Included	2
#6	M-1614	3†	25Cl	Included	2
#4 Sol	M-1615	3†	45Cl	Included	2
#4	M-1616	3†	45Cl	Included	2
#2 Sol	M-1617	3†	45Cl	Included	2
#2	M-1618	3†	45Cl	Included	2
#1 Sol	M-1619	3†	65Cl	Included	4
#1	M-1620	3†	65Cl	Included	4

Section 2 - Molds  
AWG Conductors

# CS-4

## TYPE MOLDS

### Vertical Thru Cable to Vertical Steel Surface

#### For AWG Conductors

Note that the cable is **OFF** the surface

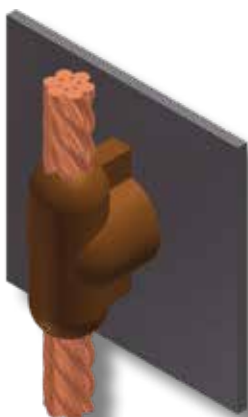

MOLDS FOR AWG CONDUCTORS										
Cable Size	STANDARD CONNECTION					HEAVY DUTY CONNECTION				
	Mold #	Price Key	Weld Metal	Handle Clamps	Lead Time	Mold #	Price Key	Weld Metal	Handle Clamps	Lead Time
#6	M-1215	4	90	B-106	2	M-1215-H	17	200	B-106	4
#4	M-1216	4	90	B-106	2	M-1216-H	17	200	B-106	4
#2	M-1218	4	115	B-106	2	M-1218-H	17	250	B-106	4
#1	M-1219	4	115	B-106	2	M-1219-H	17	250	B-106	4
1/0	M-1220	17	200	B-106	2	M-1220-H	6	2-200	B-107	4
2/0	M-1221	17	200	B-106	2	M-1221-H	6	2-200	B-107	2
3/0	M-1222	17	250	B-106	2	M-1222-H	6	500	B-107	4
4/0	M-1223	17	250	B-106	2	M-1223-H	6	500	B-107	2
250 MCM	M-1224	17	250	B-106	2	M-1224-H	6	500	B-107	4
300 MCM	Use Heavy Duty Molds					M-1225-H	6	500	B-107	2
350 MCM						M-1226-H	6	3-200	B-107	2
500 MCM						M-1228-H	6	3-250	B-107	2

**Welding to Vertical Pipe:** To weld to vertical pipe, add pipe size to mold number. Example: To weld 4/0 str cable to 6" vertical pipe, the mold number would be M-1223-V6. To weld #1 cable or smaller to pipe 14" and larger, use flat surface mold. For 1/0 cable and larger, use flat surface mold only on pipe 30" and larger.

- For sizes not listed, contact thermOweld®.
- Molds listed are for concentric stranded cable. Add suffix "-S" to mold number for solid conductors.
- For molds with wear plates, see page 135.
- For expedited service, contact thermOweld®.
- To order weld metal for use with EZ Lite Remote® insert TW before and EZ after weld metal number.
- Required Tools;
  - Handle Clamps w/ Flint Ignitor (see chart for correct handles)
  - † ~ Sold complete with frame
  - 38-0309-00 ~ Flint Ignitor or 38-EZLT-RU EZ Lite Remote®
- Other recommended accessories;
  - 40-0319-01 ~ Mold Cleaner for cartridge sizes #15-#65 (CS-5 Mold Only)
  - 38-3922-00 ~ Mold Cleaning Brush
  - 38-0135-00 ~ Cable Cleaning Brush
  - 38-0101-00 ~ Rasp
  - 38-4129-00 ~ Packing Material for 1/0 & Larger Molds (CS-5 Molds Only)

## CS-6

### TYPE MOLDS

#### Horizontal Thru Cable to Vertical Steel Surface

#### For AWG Conductors

Note that the cable is **OFF** the surface

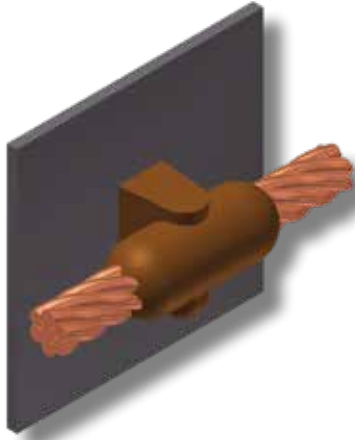

Section 2 - Molds  
AWG Conductors

#### MOLDS FOR AWG CONDUCTORS

Cable Size	Mold #	Price Key	Weld Metal	Handle Clamps	Lead Time
#6	M-1626	4	65	B-106	2
#4	M-1627	4	65	B-106	2
#2	M-1628	4	65	B-106	2
#1	M-1629	4	90	B-106	2
1/0	M-1630	4	115	B-106	2
2/0	M-1631	4	115	B-106	2
3/0	M-1632	4	150	B-106	2
4/0	M-1633	4	150	B-106	2
250 MCM	M-1634	4	150	B-106	2

**Welding to Vertical Pipe:** To weld to vertical pipe, add pipe size to mold number. Example: To weld 4/0 str cable to 6" vertical pipe, the mold number would be M-1633-V6. To weld #1 cable or smaller to pipe 14" and larger, use flat surface mold. For 1/0 cable and larger, use flat surface mold only on pipe 30" and larger.

## CS-18

### TYPE MOLDS

#### Horizontal Tap Cable to Vertical Steel Surface

#### For AWG Conductors

Note that the cable is **ON** the surface

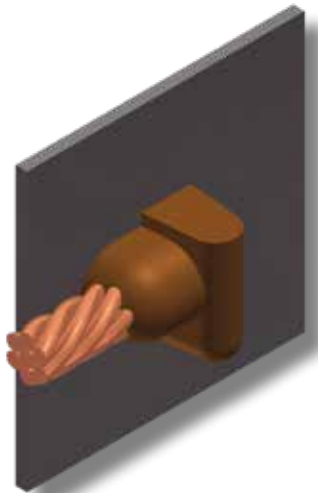

Left Hand  
Mold



Right Hand  
Mold

#### MOLDS FOR AWG CONDUCTORS

Cable Size	Mold #†	Price Key	Weld Metal	Handle Clamps	Lead Time
#6	M-5910	4	45	B-106	2
#4	M-2761	4	45	B-106	2
#2	M-2569	4	45	B-106	2
#1	M-6060	4	65	B-106	2
1/0	M-5419	4	90	B-106	2
2/0	M-2567	4	90	B-106	2
3/0	M-6072	4	115	B-106	2
4/0	M-9253	4	115	B-106	2
250 MCM	M-2568	4	115	B-106	2
300 MCM	M-6061	4	150	B-106	4
350 MCM	M-6067	4	200	B-106	2
500 MCM	M-8359	4	200	B-106	2

† Add (-R) to mold number for right hand mold or (-L) for left hand mold. Right hand (-R) mold will be furnished if not specified.

**Welding to Horizontal Pipe:** To weld to horizontal pipe, add pipe size to mold number. Example: To weld 4/0 str cable to 6" horizontal pipe, the mold number would be M-9253-L6.

- For sizes not listed, contact thermOweld®.
- Molds listed are for concentric stranded cable. Add suffix "-S" to mold number for solid conductors.
- For heavy duty connections, contact thermOweld®.
- For molds with wear plates, see page 135.
- For expedited service, contact thermOweld®.
- To order weld metal for use with EZ Lite Remote® insert TW before and EZ after weld metal number.
- Required Tools;
  - Handle Clamps w/ Flint Ignitor (see chart for correct handles)
  - 38-0309-00 ~ Flint Ignitor or 38-EZLT-RU EZ Lite Remote®
- Other recommended accessories;
  - 40-0319-01 ~ Mold Cleaner for cartridge sizes #15-#65 (CS-6 Molds Only)
  - 40-0319-03 ~ Mold Cleaner for cartridge sizes #90-#500 (CS-6 Molds Only)
  - 38-3922-00 ~ Mold Cleaning Brush
  - 38-0135-00 ~ Cable Cleaning Brush
  - 38-0101-00 ~ Rasp
  - 38-4129-00 ~ Packing Material for 1/0 & Larger Molds (CS-18 Molds Only)

# CS-7

## TYPE MOLDS

### Overhead Vertical Tap Cable to Vertical Steel Surface For AWG Conductors

Note that the cable is **ON** the surface



Section 2 - Molds  
AWG Conductors

MOLDS FOR AWG CONDUCTORS										
Cable Size	STANDARD CONNECTION					HEAVY DUTY CONNECTION				
	Mold #	Price Key	Weld Metal	Handle Clamps	Lead Time	Mold #	Price Key	Weld Metal	Handle Clamps	Lead Time
#6	M-1635	4	65	B-106	2	M-1635-H	4	90	B-106	4
#4	M-1636	4	65	B-106	2	M-1636-H	4	115	B-106	2
#2	M-1638	4	65	B-106	2	M-1638-H	4	115	B-106	2
#2 SOL	M-1638-S	4	65	B-106	2	M-1638-HS	4	115	B-106	2
#1	M-1639	4	90	B-106	2	M-1639-H	4	150	B-106	4
1/0	M-1640	4	150	B-106	2	M-1640-H	17	200	B-106	4
2/0	M-1641	4	150	B-106	2	M-1641-H	17	200	B-106	2
3/0	M-1642	17	200	B-106	2	M-1642-H	17	250	B-106	4
4/0	M-1643	17	200	B-106	2	M-1643-H	17	250	B-106	2
250 MCM	M-1644	17	200	B-106	2	M-1644-H	6	2-150	B-107	4
300 MCM	M-1645	17	250	B-106	4	M-1645-H	6	2-200	B-107	4
350 MCM	M-1646	6	2-150	B-107	2	M-1646-H	6	500	B-107	4
500 MCM	M-1648	6	2-200	B-107	2	M-1648-H	6	3-200	B-107	4
750 MCM	M-1649	6	500	B-107	2	Not Available				
1000 MCM	M-1650	6	3-200	B-107	2					

- For sizes not listed, contact thermOweld®.
- Molds listed are for concentric stranded cable. Add suffix "-S" to mold number for solid conductors.
- For expedited service, contact thermOweld®.
- To order weld metal for use with EZ Lite Remote® insert TW before and EZ after weld metal number.
- Required Tools;
  - Handle Clamps w/ Flint Ignitor (see chart for correct handles)
  - 38-0309-00 ~ Flint Ignitor or 38-EZLT-RU EZ Lite Remote®
- Other recommended accessories;
  - 40-4431-00 ~ Magnetic Handle Clamp w/ B-106 Handles
  - 38-3922-00 ~ Mold Cleaning Brush
  - 38-0135-00 ~ Cable Cleaning Brush
  - 38-0101-00 ~ Rasp

**Welding to Vertical Pipe:** To weld to vertical pipe, add pipe size to mold number. Example: To weld 4/0 str cable to 6" vertical pipe, the mold number would be M-1643-V6. To weld #1 cable or smaller to pipe 14" and larger, use flat surface mold. For 1/0 cable and larger, use flat surface mold only on pipe 30" and larger.

## CB-1

### TYPE MOLDS

#### Horizontal Cable Tap to Horizontal Lug or Bus

#### For AWG Conductors

See pages 159-160 for Lug part numbers.

Section 2 - Molds  
AWG Conductors

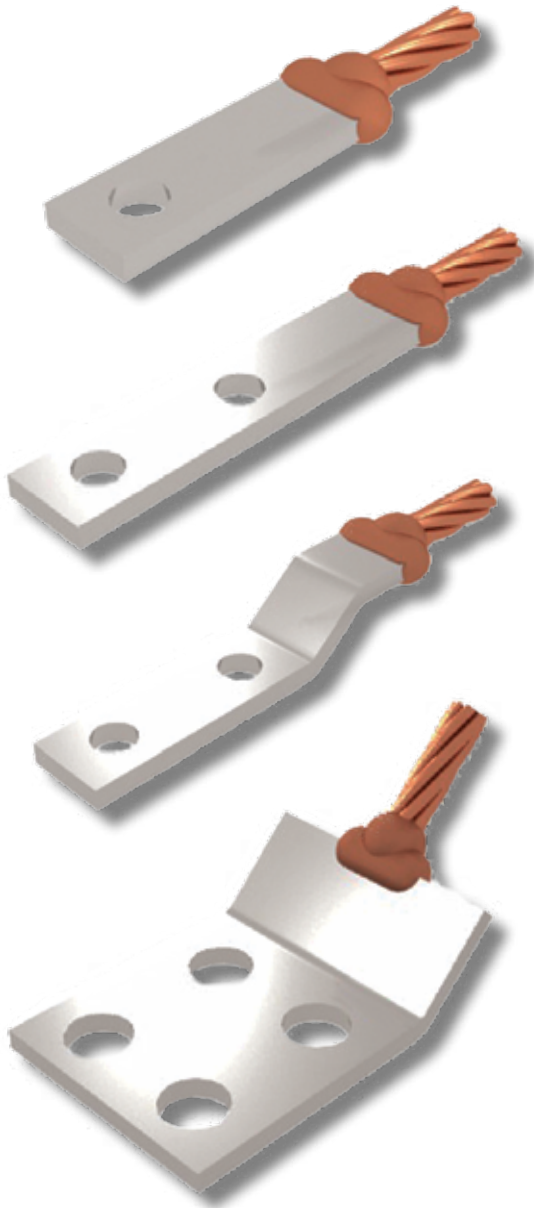

Examples of connections with available lug configurations. See pages 159-160 for Lug part nos.

MOLDS FOR AWG CONDUCTORS						
Cable Size	Lug Size	Mold #	Price Key	Weld Metal	Handle Clamps	Lead Time
#8	1/16 X 1/2	M-966	4	15	B-106	4
	1/8 X 1	M-967	4	45	B-106	2
#6	1/16 X 1/2	M-968	4	15	B-106	4
	1/8 X 1	M-969	4	45	B-106	2
#4	1/8 X 9/16	M-970	4	25	B-106	2
	1/8 X 1	M-971	4	45	B-106	2
#2	1/8 X 5/8	M-974	4	32	B-106	2
	1/8 X 1	M-975	4	45	B-106	2
#1	1/8 X 5/8	M-976	4	32	B-106	4
	1/8 X 1	M-977	4	45	B-106	2
1/0	1/8 X 1	M-978	4	45	B-106	2
	1/4 X 1	M-979	4	65	B-106	2
2/0	1/8 X 1	M-980	4	65	B-106	2
	1/4 X 1	M-981	4	65	B-106	2
3/0	3/16 X 1	M-982	4	90	B-106	2
	1/4 X 1	M-983	4	90	B-106	2
4/0	3/16 X 1	M-984	4	90	B-106	2
	1/4 X 1	M-985	4	90	B-106	2
	1/4 X 1-1/4	M-986	4	90	B-106	2
	1/4 X 1-1/2	M-987	4	90	B-106	2
250 MCM	1/4 X 3	M-1915	4	90	B-106	2
	1/4 X 1	M-988	4	90	B-106	2
	1/4 X 1-1/4	M-989	4	90	B-106	4
	1/4 X 1-1/2	M-990	4	90	B-106	2
300 MCM	1/4 X 3	M-1916	4	90	B-106	2
	1/4 X 1	M-991	4	90	B-106	2
	1/4 X 1-1/4	M-992	4	90	B-106	4
	1/4 X 1-1/2	M-993	4	90	B-106	2
350 MCM	1/4 X 3	M-1917	4	90	B-106	4
	1/4 X 1	M-994	4	115	B-106	2
	1/4 X 1-1/4	M-995	4	115	B-106	2
	1/4 X 3	M-1918	4	115	B-106	4
500 MCM	1/4 X 1-1/2	M-1001	4	200	B-106	2
	1/4 X 2	M-1002	4	200	B-106	2
	1/4 X 3	M-1920	4	200	B-106	2
	3/8 X 1	M-1003	4	200	B-106	4
	3/8 X 1-1/2	M-1004	4	200	B-106	2
750 MCM	3/8 X 2	M-1005	5	2-150	B-107	4
	1/4 X 2	M-1006	5	2-150	B-107	2
	3/8 X 1-1/2	M-1007	5	2-150	B-107	2
	3/8 X 2	M-1008	5	2-150	B-107	2
1000 MCM	3/8 X 3	M-1921	5	2-150	B-107	4
	3/8 X 2	M-1009	5	2-200	B-107	4
	3/8 X 3	M-1922	5	2-200	B-107	4
	7/16 X 2	M-1010	5	2-200	B-107	4
	1/2 X 2	M-1011	5	500	B-107	2

- For sizes not listed, contact thermOweld®.
- Molds listed are for concentric stranded cable. Add suffix "-S" to mold number for solid conductors.
- For molds with wear plates, see page 135.
- For heavy duty connections or molds with wear plates, contact thermOweld®.
- To order weld metal for use with EZ Lite Remote® insert TW before and EZ after weld metal number.
- Required Tools;
  - Handle Clamps w/ Flint Ignitor (see chart for correct handles), 38-0309-00 ~ Flint Ignitor or 38-EZLT-RU EZ Lite Remote®
- Other recommended accessories;
  - 38-3922-00 ~ Mold Cleaning Brush, 38-0135-00 ~ Cable Cleaning Brush



**CB-33**

**TYPE MOLDS**

*Horizontal Cable Tap to Horizontal Lug or Bus*

For AWG Conductors

See page 161 for Lug part numbers.

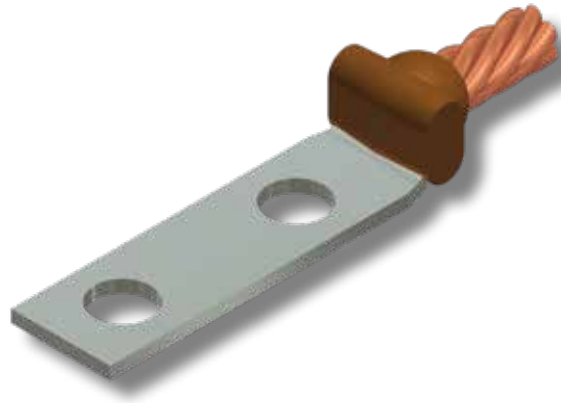

MOLDS FOR AWG CONDUCTORS						
Cable Size	Lug Size (See Lugs Below)	Mold #	Price Key	Weld Metal	Handle Clamps	Lead Time
#4	1/8 X 1	M-2035	4	32	B-106	2
#2 Sol	1/8 X 1	M-2036-S	4	32	B-106	2
#2	1/8 X 1	M-2036	4	32	B-106	2
#1	1/8 X 1	M-2037	4	32	B-106	2
1/0	1/8 X 1	M-2038	4	45	B-106	2
2/0	1/8 X 1	M-2039	4	45	B-106	2
4/0	3/16 X 1	M-2041	4	65	B-106	2
250 MCM	3/16 X	M-2042	4	65	B-106	2
300 MCM	1/4 X 1	M-2043	4	90	B-106	2
350 MCM	1/4 X 1	M-2044	4	90	B-106	4
500 MCM	1/4 X 1-1/2	M-2045	4	150	B-106	2

- For sizes not listed, contact thermOweld®.
- For heavy duty connections or molds with wear plates, contact thermOweld®.
- For expedited service, contact thermOweld®.
- To order weld metal for use with EZ Lite Remote® insert TW before and EZ after weld metal number.
- Required Tools;
  - Handle Clamps w/ Flint Ignitor (see chart for correct handles) 38-0309-00 ~ Flint Ignitor or 38-EZLT-RU EZ Lite Remote®
- Other recommended accessories;
  - 38-3922-00 ~ Mold Cleaning Brush
  - 38-0135-00 ~ Cable Cleaning Brush

## CB-4

### TYPE MOLDS

*Horizontal Cable Tap to Horizontal Bus  
For AWG Conductors*

Section 2 - Molds  
AWG Conductors

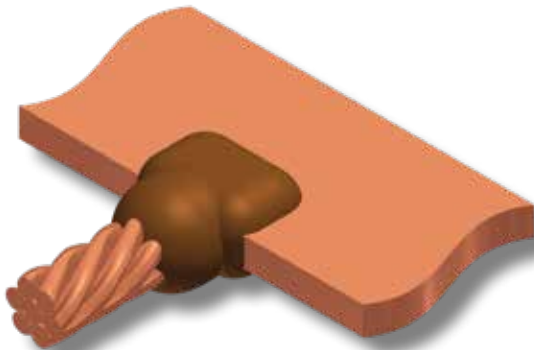

MOLDS FOR AWG CONDUCTORS						
Bus Bar Size	Cable Size	Mold #	Price Key	Weld Metal	Handle Clamps	Lead Time
1/4 X 1-1/2 & WIDER	#2	M-5415	4	65	B-106	2
	#2 Sol	M-5415-S	4	65	B-106	SDS
	1/0	M-1651	4	90	B-106	2
	2/0	M-1652	4	90	B-106	2
	3/0	M-1653	4	90	B-106	2
	4/0	M-1654	4	90	B-106	2
	250 MCM	M-1655	4	115	B-106	2
	300 MCM	M-1656	4	115	B-106	2
	350 MCM	M-1657	4	150	B-106	2
3/8 X 1-1/2 & WIDER	1/0	M-1660	4	90	B-106	2
	2/0	M-1661	4	90	B-106	2
	3/0	M-1662	4	115	B-106	2
	4/0	M-1663	4	115	B-106	2
	250 MCM	M-1664	4	150	B-106	4
	300 MCM	M-1665	4	150	B-106	4
	350 MCM	M-1666	4	200	B-106	4
	500 MCM	M-1668	4	250	B-106	2
	750 MCM	M-1669	5	2-150	B-107	2
1000 MCM	M-1670	5	2-200	B-107	4	
1/2 X 1-1/2 & WIDER	1/0	M-1671	4	115	B-106	2
	2/0	M-1672	4	115	B-106	2
	3/0	M-1673	4	150	B-106	2
	4/0	M-1674	4	150	B-106	2
	250 MCM	M-1675	4	200	B-106	4
	300 MCM	M-1676	4	200	B-106	4
	350 MCM	M-1677	4	250	B-106	2
	500 MCM	M-1679	5	2-150	B-107	2
	750 MCM	M-1680	5	2-200	B-107	4
1000 MCM	M-1681	5	500	B-107	4	

- For sizes not listed, contact thermOweld®.
- Molds listed are for concentric stranded cable. Add suffix "-S" to mold number for solid conductors.
- For heavy duty connections, contact thermOweld®.
- For expedited service, contact thermOweld®.
- To order weld metal for use with EZ Lite Remote® insert TW before and EZ after weld metal number.
- Required Tools;
  - Handle Clamps w/ Flint Ignitor (see chart for correct handles)
  - 38-0309-00 ~ Flint Ignitor or 38-EZLT-RU EZ Lite Remote®
- Other recommended accessories;
  - 40-0319-01 ~ Mold Cleaner for cartridge sizes #15-#65
  - 40-0319-03 ~ Mold Cleaner for cartridge sizes #90-#500
  - 38-3922-00 ~ Mold Cleaning Brush
  - 38-0135-00 ~ Cable Cleaning Brush

# CB-2

## TYPE MOLDS

*Vertical Overhead Tap to Horizontal Bus  
For AWG Conductors*

MOLDS FOR AWG CONDUCTORS						
Bus Bar Size	Cable Size	Mold #	Price Key	Weld Metal	Handle Clamps	Lead Time
1/8 X 1	1/0	M-830	4	115	B-106	4
	2/0	M-831	4	115	B-106	4
	4/0	M-832	4	115	B-106	2
1/8 X 1-1/2 & WIDER	#2	M-7365	17	65	B-106	2
	1/0	M-833	4	115	B-106	2
	2/0	M-834	4	115	B-106	4
	4/0	M-835	4	115	B-106	2
	250 MCM	M-836	4	115	B-106	4
	300 MCM	M-837	4	150	B-106	4
	350 MCM	M-838	4	150	B-106	2
1/4 X 1	#2	M-7167	17	90	B-106	4
	1/0	M-839	4	150	B-106	2
	2/0	M-840	4	150	B-106	2
	4/0	M-841	4	150	B-106	2
	250 MCM	M-842	4	150	B-106	2
	300 MCM	M-843	4	200	B-106	4
	350 MCM	M-844	4	200	B-106	2
	500 MCM	M-846	4	2-150	B-106	4
1/4 X 1-1/2 & WIDER	#2	M-6366	17	90	B-106	2
	1/0	M-847	4	150	B-106	2
	2/0	M-848	4	150	B-106	2
	4/0	M-849	4	150	B-106	2
	250 MCM	M-850	4	150	B-106	2
	300 MCM	M-851	4	200	B-106	2
	350 MCM	M-852	4	200	B-106	2
	500 MCM	M-854	4	2-150	B-106	2
	750 MCM	M-855	5	2-200	B-107	2
3/8 X 1	1/0	M-857	4	150	B-106	2
	2/0	M-858	4	150	B-106	2
	4/0	M-859	4	150	B-106	4
	250 MCM	M-860	4	150	B-106	4
	300 MCM	M-861	4	200	B-106	4
	350 MCM	M-862	4	200	B-106	4
	500 MCM	M-864	4	250	B-106	4
	750 MCM	M-865	5	2-200	B-107	4
3/8 X 1-1/2 & WIDER	1/0	M-867	4	150	B-106	2
	2/0	M-868	4	150	B-106	2
	4/0	M-869	4	150	B-106	2
	250 MCM	M-870	4	150	B-106	4
	300 MCM	M-871	4	200	B-106	4
	350 MCM	M-872	4	200	B-106	4
1/2 X 1	1/0	M-877	4	200	B-106	4
	2/0	M-878	4	200	B-106	4
	4/0	M-879	4	200	B-106	4
	250 MCM	M-880	4	200	B-106	4
	300 MCM	M-881	4	250	B-106	4
	350 MCM	M-882	4	250	B-106	4
1/2 X 1-1/2 & WIDER	500 MCM	M-884	5	2-150	B-107	4
	750 MCM	M-885	5	500	B-107	4
	1/0	M-887	4	200	B-106	2
	2/0	M-888	4	200	B-106	2
	4/0	M-889	4	200	B-106	2
	250 MCM	M-890	4	200	B-106	4
	300 MCM	M-891	4	250	B-106	4
	350 MCM	M-892	4	250	B-106	4
500 MCM	M-894	5	2-150	B-107	2	
750 MCM	M-895	5	500	B-107	4	



- For sizes not listed, contact thermOweld®.
- Molds listed are for concentric stranded cable. Add suffix "-S" to mold number for solid conductors.
- For heavy duty connections, contact thermOweld®.
- For expedited service, contact thermOweld®.
- To order weld metal for use with EZ Lite Remote® insert RW before and EZ after weld metal number.
- Required Tools;
  - Handle Clamps w/ Flint Ignitor (see chart for correct handles)
  - 38-0309-00 ~ Flint Ignitor or 38-EZLT-RU EZ Lite Remote®
- Other recommended accessories;
  - 38-3922-00 ~ Mold Cleaning Brush
  - 38-0135-00 ~ Cable Cleaning Brush

Section 2 - Molds  
AWG Conductors

## CB-6

### TYPE MOLDS

#### Vertical Overhead Tap to Horizontal Bus For AWG Conductors

CB-6 Type Molds are use where there are **space restrictions** such as another surface  $\frac{3}{4}$ " to 5" from the bus bar.



Section 2 - Molds  
AWG Conductors

### MOLDS FOR AWG CONDUCTORS

Bus Bar Size	Cable Size	Mold #	Price Key	Weld Metal	Handle Clamps	Lead Time
1/8 X 1	1/0	M-898	7†	115	B-106	4
	2/0	M-899	7†	115	B-106	4
	4/0	M-900	7†	115	B-106	4
1/8 X 1-1/2 & WIDER	#2	M-5198	7†	65	B-106	2
	1/0	M-901	7†	115	B-106	4
	2/0	M-902	7†	115	B-106	4
	4/0	M-903	7†	115	B-106	4
	250 MCM	M-904	7†	115	B-106	4
	300 MCM	M-905	7†	150	B-106	2
350 MCM	M-906	7†	150	B-106	4	
1/4" X 1	1/0	M-907	7†	150	B-106	2
	2/0	M-908	7†	150	B-106	4
	4/0	M-909	7†	150	B-106	4
	250 MCM	M-910	7†	150	B-106	4
	300 MCM	M-911	7†	200	B-106	4
	350 MCM	M-912	7†	200	B-106	4
500 MCM	M-914	7†	2-150	B-106	4	
1/4 X 1-1/2 & WIDER	#2	M-6967	7†	90	B-106	2
	1/0	M-915	7†	150	B-106	2
	2/0	M-916	7†	150	B-106	4
	4/0	M-917	7†	150	B-106	2
	250 MCM	M-918	7†	150	B-106	2
	300 MCM	M-919	7†	200	B-106	4
	350 MCM	M-920	7†	200	B-106	4
	500 MCM	M-922	7†	2-150	B-106	2
750 MCM	M-923	8†	2-200	B-107	4	
3/8 X 1	1/0	M-925	7†	150	B-106	4
	2/0	M-926	7†	150	B-106	4
	4/0	M-927	7†	150	B-106	4
	250 MCM	M-928	7†	150	B-106	4
	300 MCM	M-929	7†	200	B-106	4
	350 MCM	M-930	7†	200	B-106	4
	500 MCM	M-932	7†	250	B-106	4
	750 MCM	M-933	8†	2-200	B-107	4
3/8 X 1-1/2 & WIDER	1/0	M-935	7†	150	B-106	4
	2/0	M-936	7†	150	B-106	2
	4/0	M-937	7†	150	B-106	4
	250 MCM	M-938	7†	150	B-106	4
	300 MCM	M-939	7†	200	B-106	4
	350 MCM	M-940	7†	200	B-106	4
500 MCM	M-942	7†	250	B-106	4	
750 MCM	M-943	8†	2-200	B-107	4	
1/2 X 1	1/0	M-945	7†	200	B-106	4
	2/0	M-946	7†	200	B-106	4
	4/0	M-947	7†	200	B-106	4
	250 MCM	M-948	7†	200	B-106	4
	300 MCM	M-949	7†	250	B-106	4
	350 MCM	M-950	7†	250	B-106	4
500 MCM	M-952	8†	2-150	B-107	4	
750 MCM	M-953	8†	500	B-107	4	
1/2 X 1-1/2 & WIDER	1/0	M-955	7†	200	B-106	4
	2/0	M-956	7†	200	B-106	4
	4/0	M-957	7†	200	B-106	4
	250 MCM	M-958	7†	200	B-106	4
	300 MCM	M-959	7†	250	B-106	4
	350 MCM	M-960	7†	250	B-106	4
500 MCM	M-962	8†	2-150	B-107	4	
750 MCM	M-963	8†	500	B-107	4	

- For sizes not listed, contact thermOweld®.
- Molds listed are for concentric stranded cable. Add suffix "-S" to mold number for solid conductors.
- For heavy duty connections, contact thermOweld®.
- For expedited service, contact thermOweld®.
- To order weld metal for use with EZ Lite Remote® insert TW before and EZ after weld metal number.
- Required Tools;
  - Handle Clamps w/ Flint Ignitor (see chart for correct handles)
  - † ~ Sold complete with frame
  - 38-0309-00 ~ Flint Ignitor or 38-EZLT-RU EZ Lite Remote®
- Other recommended accessories;
  - 38-3922-00 ~ Mold Cleaning Brush
  - 38-0135-00 ~ Cable Cleaning Brush

CB-3

TYPE MOLDS

Vertical Drop Tap to Horizontal Bus  
For AWG Conductors

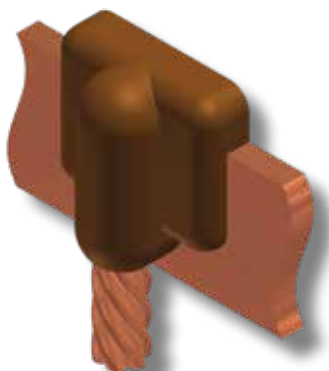

MOLDS FOR AWG CONDUCTORS						
Bus Bar Size	Cable Size	Mold #	Price Key	Weld Metal	Handle Clamps	Lead Time
1/8 X 1	1/0	M-656	4	90	B-106	4
	2/0	M-657	4	90	B-106	4
	4/0	M-658	4	115	B-106	2
1/8 X 2	1/0	M-659	4	90	B-106	4
	2/0	M-660	4	90	B-106	4
	4/0	M-661	4	115	B-106	2
	250 MCM	M-662	4	115	B-106	2
	300 MCM	M-663	4	150	B-106	2
1/4 X 1	#2	M-6694	4	90	B-106	4
	1/0	M-665	4	115	B-106	2
	2/0	M-666	4	115	B-106	4
	4/0	M-667	4	150	B-106	2
	250 MCM	M-668	4	150	B-106	4
	300 MCM	M-669	4	200	B-106	4
	350 MCM	M-670	4	200	B-106	4
1/4 X 1-1/2	#2	M-6658	4	90	B-106	2
	1/0	M-673	4	115	B-106	4
	2/0	M-674	4	115	B-106	2
	4/0	M-675	4	150	B-106	2
	250 MCM	M-676	4	150	B-106	4
	300 MCM	M-677	4	200	B-106	4
	350 MCM	M-678	4	200	B-106	4
	500 MCM	M-680	4	250	B-106	4
1/4 X 2	#2	M-5567	4	90	B-106	2
	1/0	M-682	4	115	B-106	2
	2/0	M-683	4	115	B-106	2
	4/0	M-684	4	150	B-106	2
	250 MCM	M-685	4	150	B-106	4
	300 MCM	M-686	4	200	B-106	2
	350 MCM	M-687	4	200	B-106	4
	500 MCM	M-689	4	250	B-106	2
	750 MCM	M-690	5	2-200	B-107	4
	1000 MCM	M-691	5	500	B-107	4
1/4 X 3 & WIDER	#2	M-5944	4	90	B-106	2
	1/0	M-692	4	115	B-106	2
	2/0	M-693	4	115	B-106	2
	4/0	M-694	4	150	B-106	2
	250 MCM	M-695	4	150	B-106	2
	300 MCM	M-696	4	200	B-106	2
	350 MCM	M-697	4	200	B-106	2
	500 MCM	M-699	4	250	B-106	2
	750 MCM	M-700	5	2-200	B-107	2
	1000 MCM	M-701	5	500	B-107	4

MOLDS FOR AWG CONDUCTORS						
Bus Bar Size	Cable Size	Mold #	Price Key	Weld Metal	Handle Clamps	Lead Time
3/8 X 2	1/0	M-702	4	115	B-106	4
	2/0	M-703	4	115	B-106	4
	4/0	M-704	4	150	B-106	4
	250 MCM	M-705	4	150	B-106	4
	300 MCM	M-706	4	200	B-106	4
	350 MCM	M-707	4	200	B-106	4
	500 MCM	M-709	4	250	B-106	2
	750 MCM	M-710	5	2-200	B-107	4
3/8 X 2 & WIDER	1/0	M-712	4	115	B-106	2
	2/0	M-713	4	115	B-106	4
	4/0	M-714	4	150	B-106	2
	250 MCM	M-715	4	150	B-106	4
	300 MCM	M-716	4	200	B-106	4
	350 MCM	M-717	4	200	B-106	4
	500 MCM	M-719	4	250	B-106	4
	750 MCM	M-720	5	2-200	B-107	4
	1000 MCM	M-721	5	500	B-107	4
	1/2 X 2	1/0	M-722	4	150	B-106
2/0		M-723	4	150	B-106	4
4/0		M-724	4	200	B-106	4
250 MCM		M-725	4	200	B-106	4
300 MCM		M-726	4	250	B-106	4
350 MCM		M-727	4	250	B-106	4
500 MCM		M-729	4	2-150	B-106	4
750 MCM		M-730	5	500	B-107	4
1000 MCM		M-731	5	3-200	B-107	4
1/2 X 3 & WIDER		1/0	M-732	4	150	B-106
	2/0	M-733	4	150	B-106	4
	4/0	M-734	4	200	B-106	2
	250 MCM	M-735	4	200	B-106	4
	300 MCM	M-736	4	250	B-106	4
	350 MCM	M-737	4	250	B-106	4
	500 MCM	M-739	5	2-150	B-107	2
	750 MCM	M-740	5	500	B-107	4
	1000 MCM	M-741	5	3-200	B-107	4

- For sizes not listed, contact thermOweld®.
- Molds listed are for concentric stranded cable. Add suffix "-S" to mold number for solid conductors.
- For heavy duty connections, contact thermOweld®.
- For expedited service, contact thermOweld®.
- To order weld metal for use with EZ Lite Remote® insert TW before and EZ after weld metal number.
- Required Tools;
  - Handle Clamps w/ Flint Ignitor (see chart for correct handles)
  - 38-0309-00 ~ Flint Ignitor or 38-EZLT-RU EZ Lite Remote®
- Other recommended accessories;
  - 38-3922-00 ~ Mold Cleaning Brush
  - 38-0135-00 ~ Cable Cleaning Brush

Section 2 - Molds  
AWG Conductors

## CB-7

### TYPE MOLDS

#### Vertical Drop Tap to Horizontal Bus

#### For AWG Conductors

CB-7 Type Molds are used where there are **space restrictions** such as another surface  $\frac{3}{4}$ " to 5" from the bus bar.



Section 2 - Molds  
AWG Conductors

MOLDS FOR AWG CONDUCTORS						
Bus Bar Size	Cable Size	Mold #	Price Key	Weld Metal	Handle Clamps	Lead Time
1/8 X 1	1/0	M-743	7†	90	B-106	4
	2/0	M-744	7†	90	B-106	4
	4/0	M-745	7†	115	B-106	2
1/8 X 2	1/0	M-746	7†	90	B-106	4
	2/0	M-747	7†	90	B-106	4
	4/0	M-748	7†	115	B-106	4
	250 MCM	M-749	7†	115	B-106	4
	300 MCM	M-750	7†	150	B-106	4
	350 MCM	M-751	7†	150	B-106	4
1/4 X 1	#2 STR	M-8550	7†	90	B-106	4
	1/0	M-752	7†	115	B-106	4
	2/0	M-753	7†	115	B-106	4
	4/0	M-754	7†	150	B-106	4
	250 MCM	M-755	7†	150	B-106	4
	300 MCM	M-756	7†	200	B-106	4
	350 MCM	M-757	7†	200	B-106	4
	500 MCM	M-759	7†	250	B-106	4
1/4 X 1-1/2	#2	M-8551	7†	90	B-106	4
	1/0	M-760	7†	115	B-106	2
	2/0	M-761	7†	115	B-106	4
	4/0	M-762	7†	150	B-106	4
	250 MCM	M-763	7†	150	B-106	4
	300 MCM	M-764	7†	200	B-106	4
	350 MCM	M-765	7†	200	B-106	4
	500 MCM	M-767	7†	250	B-106	4
	750 MCM	M-768	8†	2-200	B-107	4
1/4 X 2	#2	M-5469	7†	90	B-106	2
	1/0	M-769	7†	115	B-106	4
	2/0	M-770	7†	115	B-106	4
	4/0	M-771	7†	150	B-106	2
	250 MCM	M-772	7†	150	B-106	2
	300 MCM	M-773	7†	200	B-106	4
	350 MCM	M-774	7†	200	B-106	4
	500 MCM	M-776	7†	250	B-106	4
	750 MCM	M-777	8†	2-200	B-107	4
1000 MCM	M-778	8†	500	B-107	4	
1/4 X 3 & WIDER	#2	M-8396	7†	90	B-106	2
	1/0	M-779	7†	115	B-106	2
	2/0	M-780	7†	115	B-106	4
	4/0	M-781	7†	150	B-106	2
	250 MCM	M-782	7†	150	B-106	4
	300 MCM	M-783	7†	200	B-106	4
	350 MCM	M-784	7†	200	B-106	4
	500 MCM	M-786	7†	250	B-106	2
	750 MCM	M-787	8†	2-200	B-107	4
	1000 MCM	M-788	8†	500	B-107	4

MOLDS FOR AWG CONDUCTORS						
Bus Bar Size	Cable Size	Mold #	Price Key	Weld Metal	Handle Clamps	Lead Time
3/8 X 2	1/0	M-789	7†	115	B-106	4
	2/0	M-790	7†	115	B-106	4
	4/0	M-791	7†	150	B-106	4
	250 MCM	M-792	7†	150	B-106	4
	300 MCM	M-793	7†	200	B-106	4
	350 MCM	M-794	7†	200	B-106	4
	500 MCM	M-796	7†	250	B-106	4
	750 MCM	M-797	8†	2-200	B-107	4
	1000 MCM	M-798	8†	500	B-107	4
3/8 X 2 & WIDER	1/0	M-799	7†	115	B-106	4
	2/0	M-800	7†	115	B-106	4
	4/0	M-801	7†	150	B-106	2
	250 MCM	M-802	7†	150	B-106	4
	300 MCM	M-803	7†	200	B-106	4
	350 MCM	M-804	7†	200	B-106	4
	500 MCM	M-806	7†	250	B-106	2
	750 MCM	M-807	8†	2-200	B-107	4
	1000 MCM	M-808	8†	500	B-107	4
	1/2 X 2	1/0	M-809	7†	150	B-106
2/0		M-810	7†	150	B-106	4
4/0		M-811	7†	200	B-106	4
250 MCM		M-812	7†	200	B-106	4
300 MCM		M-813	7†	250	B-106	4
350 MCM		M-814	7†	250	B-106	4
500 MCM		M-816	7†	2-150	B-106	4
750 MCM		M-817	8†	500	B-107	4
1000 MCM		M-818	8†	3-200	B-107	4
1/2 X 3 & WIDER		1/0	M-819	7†	150	B-106
	2/0	M-820	7†	150	B-106	4
	4/0	M-821	7†	200	B-106	4
	250 MCM	M-822	7†	200	B-106	4
	300 MCM	M-823	7†	250	B-106	4
	350 MCM	M-824	7†	250	B-106	4
	500 MCM	M-826	8†	2-150	B-107	4
	750 MCM	M-827	8†	500	B-107	4
	1000 MCM	M-828	8†	3-200	B-107	4

- For sizes not listed, contact thermOweld®.
- Molds listed are for concentric stranded cable. Add suffix "-S" to mold number for solid conductors.
- For heavy duty connections, contact thermOweld®.
- For expedited service, contact thermOweld®.
- To order weld metal for use with EZ Lite Remote® insert TW before and EZ after weld metal number.
- Required Tools;
  - Handle Clamps w/ Flint Ignitor (see chart for correct handles)
  - † ~ Sold complete with frame
  - 38-0309-00 ~ Flint Ignitor or 38-EZLT-RU EZ Lite Remote®
- Other recommended accessories;
  - 38-3922-00 ~ Mold Cleaning Brush
  - 38-0135-00 ~ Cable Cleaning Brush



CB-29

TYPE MOLDS

Horizontal Bus to Vertical Cable Run  
For AWG Conductors

MOLDS FOR AWG CONDUCTORS						
Bus Bar Size	Cable Size	Mold #	Price Key	Weld Metal	Handle Clamps	Lead Time
1/4 X 2 & Wider	#2	M-6922	7†	250	B-106	2
	#2 Sol	M-6922-S	7†	250	B-106	2
	1/0	M-6758	8†	2-200	B-107	4
	2/0	M-6363	8†	2-200	B-107	2
	4/0	M-6184	8†	500	B-107	2
	250 MCM	M-9937	8†	500	B-107	2
	500 MCM	M-6183	8†	500	B-107	2
3/8 X 2 & WIDER	750 MCM	M-10543	8†	3-200	B-107	4
	#2	M-10544	7†	250	B-106	4
	#2 Sol	M-10545	7†	250	B-106	4
	1/0	M-10546	8†	2-200	B-107	4
	2/0	M-10547	8†	2-200	B-107	4
	4/0	M-10548	8†	500	B-107	4
	250 MCM	M-10549	8†	500	B-107	4
1/2 X 2 & WIDER	500 MCM	M-10550	8†	500	B-107	4
	750 MCM	M-10551	8†	3-200	B-107	4
	#2	M-10552	8†	2-150	B-107	4
	#2 Sol	M-10553	8†	2-150	B-107	4
	1/0	M-10554	8†	500	B-107	4
	2/0	M-10555	8†	500	B-107	4
	4/0	M-10556	8†	3-200	B-107	4
	250 MCM	M-10557	8†	3-200	B-107	4
	500 MCM	M-10558	8†	3-200	B-107	4
	750 MCM	M-10559	8†	3-250	B-107	4

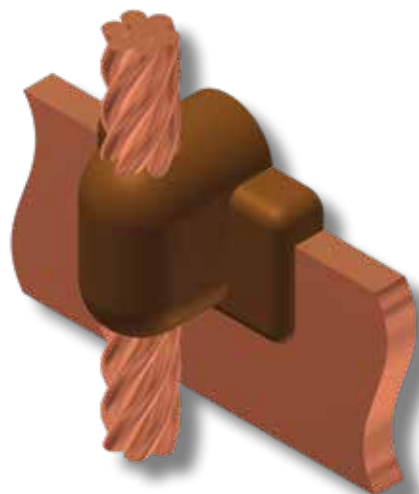

Section 2 - Molds  
AWG Conductors

- For sizes not listed, contact thermOweld®.
- Molds listed are for concentric stranded cable. Add suffix "-S" to mold number for solid conductors.
- For heavy duty connections, contact thermOweld®.
- For expedited service, contact thermOweld®.
- To order weld metal for use with EZ Lite Remote® insert TW before and EZ after weld metal number.
- Required Tools;
  - Handle Clamps w/ Flint Ignitor (see chart for correct handles)
  - † ~ Sold complete with frame
  - 38-0309-00 ~ Flint Ignitor or 38-EZLT-RU EZ Lite Remote®
- Other recommended accessories;
  - 40-0319-01 ~ Mold Cleaner for cartridge sizes #15-#65
  - 40-0319-03 ~ Mold Cleaner for cartridge sizes #90-#500
  - 38-3922-00 ~ Mold Cleaning Brush
  - 38-0135-00 ~ Cable Cleaning Brush

## CB-5

### TYPE MOLDS

*Horizontal Bus Tap to Horizontal Cable Run  
For AWG Conductors*

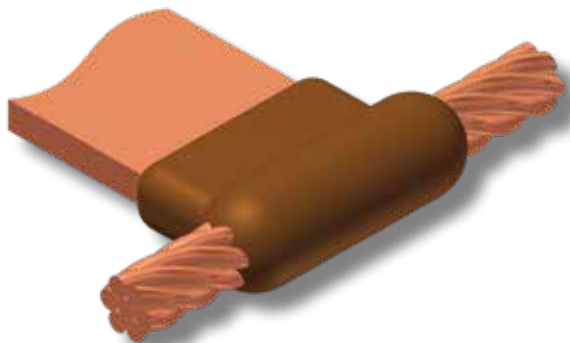

MOLDS FOR AWG CONDUCTORS						
Cable Size	Lug Size	Mold #	Price Key	Weld Metal	Handle Clamps	Lead Time
1/0	1/8 X 1	M-1682	4	65	B-106	4
	1/4 X 1	M-1683	4	90	B-106	4
2/0	1/8 X 1	M-1684	4	90	B-106	2
	1/4 X 1	M-1685	4	115	B-106	2
4/0	3/16 X 1	M-1690	4	150	B-106	2
	1/4 X 1	M-1691	4	150	B-106	2
	1/4 X 1-1/2	M-1692	4	200	B-106	4
	1/4 X 2	M-1693	4	250	B-106	2
250 MCM	1/4 X 1	M-1694	4	150	B-106	2
	1/4 X 1-1/2	M-1695	4	200	B-106	4
	1/4 X 2	M-1696	4	250	B-106	2
300 MCM	1/4 X 1	M-1697	4	200	B-106	2
	1/4 X 1-1/2	M-1698	4	250	B-106	4
	1/4 X 2	M-1699	5	2-150	B-107	4
350 MCM	1/4 X 1	M-1700	5	200	B-107	4
	1/4 X 1-1/4	M-1701	5	200	B-107	4
	1/4 X 1-1/2	M-1702	5	250	B-107	4
	1/4 X 2	M-1703	5	2-150	B-107	4
500 MCM	1/4 X 1	M-1707	5	250	B-107	2
	1/4 X 1-1/2	M-1708	5	2-150	B-107	4
	1/4 X 2	M-1709	5	2-200	B-107	4
750 MCM	1/4 X 1-1/2	M-1710	5	2-200	B-107	4
	1/4 X 2	M-1711	5	500	B-107	4
	3/8 X 1-1/2	M-1712	5	500	B-107	4
	3/8 X 2	M-1713	5	3-200	B-107	4
1000 MCM	1/4 X 1-1/2	M-1714	5	500	B-107	4
	1/4 X 2	M-1715	5	3-200	B-107	4
	3/8 X 1-1/2	M-1716	5	3-200	B-107	4
	3/8 X 2	M-1717	5	3-250	B-107	4

- For sizes not listed, contact thermOweld®.
- Molds listed are for concentric stranded cable. Add suffix "-S" to mold number for solid conductors.
- For heavy duty connections, contact thermOweld®.
- For molds with wear plates, see page 135.
- For expedited service, contact thermOweld®.
- To order weld metal for use with EZ Lite Remote® insert TW before and EZ after weld metal number.
- Required Tools;
  - Handle Clamps w/ Flint Ignitor (see chart for correct handles)
  - 38-0309-00 ~ Flint Ignitor or 38-EZLT-RU EZ Lite Remote®
- Other recommended accessories;
  - 40-0319-01 ~ Mold Cleaner for cartridge sizes #15-#65
  - 40-0319-03 ~ Mold Cleaner for cartridge sizes #90-#500
  - 38-3922-00 ~ Mold Cleaning Brush
  - 38-0135-00 ~ Cable Cleaning Brush

# BB-1

## TYPE MOLDS

*Horizontal Bus End to End*

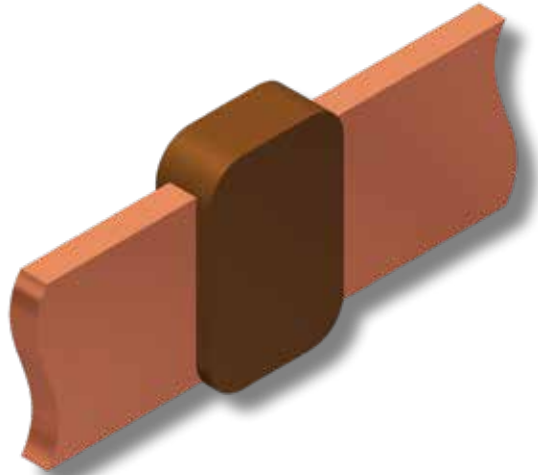

Section 2 - Molds  
AWG Conductors

Bus Bar Size	Mold #	Price Key	Weld Metal	Handle Clamps	Lead Time
1/8 X 1	M-1118	4	45	B-106	2
1/8 X 2	M-1119	4	90	B-106	2
3/16 X 1	M-1120	4	65	B-106	2
3/16 X 2	M-1121	4	115	B-106	4
1/4 X 1	M-1122	4	90	B-106	2
1/4 X 1-1/4	M-1123	4	115	B-106	2
1/4 X 1-1/2	M-1124	4	150	B-106	2
1/4 X 2	M-1125	4	200	B-106	2
1/4 X 3	M-1126	5	2-200	B-107	2
1/4 X 4	M-1127	5	500	B-107	2
3/8 X 1	M-1130	4	150	B-106	4
3/8 X 1-1/2	M-1131	4	250	B-106	4
3/8 X 2	M-1132	5	2-150	B-107	2
3/8 X 3	M-1133	5	500	B-107	4
3/8 X 4	M-1134	5	3-200	B-107	2
1/2 X 1	M-1135	4	200	B-106	4
1/2 X 2	M-1136	5	2-200	B-107	4
1/2 X 3	M-1137	5	3-200	B-107	4
1/2 X 4	M-1138	6	2-500	B-107	2

- For sizes not listed, contact thermOweld®.
- For heavy duty connections, contact thermOweld®.
- For expedited service, contact thermOweld®.
- To order weld metal for use with EZ Lite Remote® insert TW before and EZ after weld metal number.
- Required Tools;
  - Handle Clamps w/ Flint Ignitor (see chart for correct handles)
  - 38-0309-00 ~ Flint Ignitor or 38-EZLT-RU EZ Lite Remote®
- Other recommended accessories;
  - 38-3922-00 ~ Mold Cleaning Brush
  - 38-0305-00 ~ Card Cloth Brush

## BB-2

### TYPE MOLDS

*Horizontal to Vertical at Right Angle*

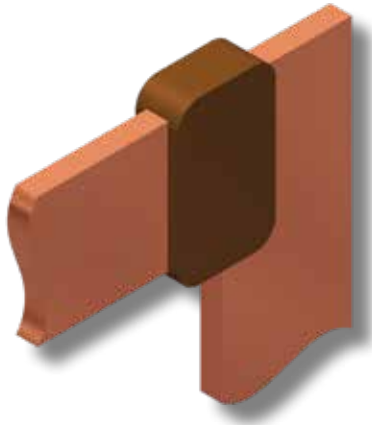

Section 2 - Molds  
AWG Conductors

Bus Bar Size	Mold #	Price Key	Weld Metal	Handle Clamps	Lead Time
1/8 X 1	M-1230	4	45	B-106	2
1/8 X 2	M-1231	4	90	B-106	4
3/16 X 1	M-1232	4	65	B-106	2
3/16 X 2	M-1233	4	115	B-106	2
1/4 X 1	M-1234	4	90	B-106	4
1/4 X 1-1/4	M-1235	4	115	B-106	4
1/4 X 1-1/2	M-1236	4	150	B-106	2
1/4 X 2	M-1237	4	200	B-106	2
1/4 X 3	M-1238	5	2-200	B-107	2
1/4 X 4	M-1239	5	500	B-107	4
3/8 X 1	M-1242	4	150	B-106	4
3/8 X 1-1/2	M-1243	4	250	B-106	4
3/8 X 2	M-1244	5	2-150	B-107	4
3/8 X 3	M-1245	5	500	B-107	4
3/8 X 4	M-1246	5	3-200	B-107	4
1/2 X 1	M-1247	4	200	B-106	4
1/2 X 2	M-1248	5	2-200	B-107	4
1/2 X 3	M-1249	5	3-200	B-107	2
1/2 X 4	M-1250	6	2-500	B-107	4

## BB-3

### TYPE MOLDS

*Vertical Drop Tap to Horizontal Run*

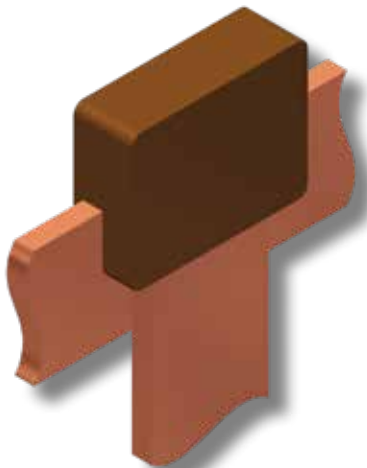

Bus Bar Size		Mold #	Price Key	Weld Metal	Handle Clamps	Lead Time
Run	Tap					
1/8 X 1	1/8 X 1	M-1098	4	90	B-106	2
1/8 X 2 & WIDER	1/8 X 2	M-1099	4	200	B-106	4
3/16 X 1	3/16 X 1	M-1100	4	115	B-106	2
3/16 X 2 & WIDER	3/16 X 2	M-1101	4	200	B-106	2
1/4 X 1	1/4 X 1	M-1102	4	150	B-106	2
1/4 X 1-1/4	1/4 X 1-1/4	M-1103	4	200	B-106	4
1/4 X 1-1/2	1/4 X 1-1/2	M-1104	4	250	B-106	2
1/4 X 2 & WIDER	1/4 X 2	M-1105	5	2-200	B-107	2
3/8 X 1	3/8 X 1	M-1108	4	250	B-106	4
3/8 X 1-1/2	3/8 X 1-1/2	M-1109	5	2-200	B-107	4
3/8 X 2 & WIDER	3/8 X 2	M-1110	5	500	B-107	4
1/2 X 1	1/2 X 1	M-1113	5	2-150	B-107	4
1/2 X 2 & WIDER	1/2 X 2	M-1114	5	3-250	B-107	4

- For sizes not listed, contact thermOweld®.
- For heavy duty connections, contact thermOweld®.
- For expedited service, contact thermOweld®.
- To order weld metal for use with EZ Lite Remote® insert TW before and EZ after weld metal number.
- Required Tools;
  - Handle Clamps w/ Flint Ignitor (see chart for correct handles)
  - 38-0309-00 ~ Flint Ignitor or 38-EZLT-RU EZ Lite Remote®
- Other recommended accessories;
  - 38-3922-00 ~ Mold Cleaning Brush
  - 38-0305-00 ~ Card Cloth Brush

# BS-1

## TYPE MOLDS

Vertical Tap to Vertical Steel Surface

Bus Bar Size	Mold #	Price Key	Weld Metal	Handle Clamps	Lead Time
1/8 X 2	M-1044	4	200	B-106	4
1/4 X 1	M-1045	4	150	B-106	2
1/4 X 1-1/4	M-1046	4	200	B-106	4
1/4 X 1-1/2	M-1047	4	250	B-106	2
1/4 X 2	M-1048	5	2-150	B-107	2
3/8 X 1	M-1049	4	200	B-106	4
3/8 X 2	M-1050	5	2-200	B-107	4
1/2 X 1	M-1051	4	250	B-106	4
1/2 X 2	M-1052	5	500	B-107	4

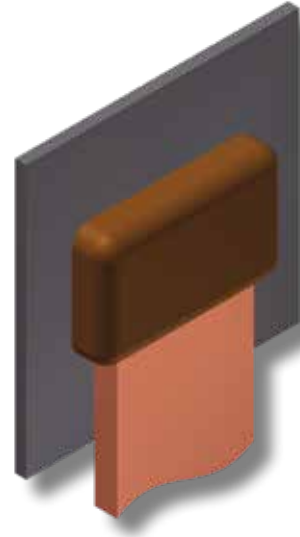

Section 2 - Molds  
AWG Conductors

# BS-2

## TYPE MOLDS

Horizontal Tap to Horizontal Steel Surface

Bus Bar Size	Mold #	Price Key	Weld Metal	Handle Clamps	Lead Time
1/8 X 1	M-1072	4	115	B-106	2
1/8 X 1-1/2	M-1073	4	150	B-106	2
1/8 X 2	M-1074	4	200	B-106	4
3/16 X 1	M-1075	4	150	B-106	2
3/16 X 2	M-1076	4	250	B-106	4
1/4 X 1	M-1077	4	150	B-106	4
1/4 X 1-1/4	M-1078	4	200	B-106	4
1/4 X 1-1/2	M-1079	4	250	B-106	4
1/4 X 2	M-1080	5	2-150	B-107	2
3/8 X 1	M-1081	4	200	B-106	2
3/8 X 1-1/2	M-1082	4	250	B-106	2
3/8 X 2	M-1083	5	2-200	B-107	2
1/2 X 1	M-1084	4	250	B-106	4
1/2 X 1-1/2	M-1085	5	2-200	B-107	4
1/2 X 2	M-1086	5	500	B-107	4

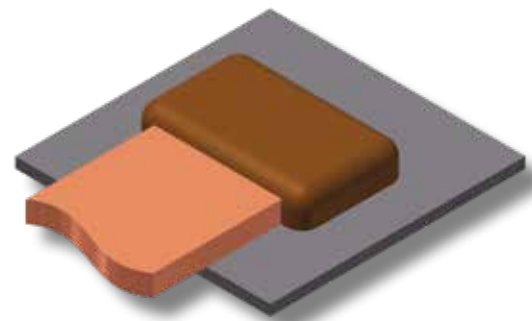

- For sizes not listed, contact thermOweld®.
- For heavy duty connections, contact thermOweld®.
- For expedited service, contact thermOweld®.
- To order weld metal for use with EZ Lite Remote® insert TW before and EZ after weld metal number.
- Required Tools;
  - Handle Clamps w/ Flint Ignitor (see chart for correct handles)
  - 38-0309-00 ~ Flint Ignitor or 38-EZLT-RU EZ Lite Remote®
- Other recommended accessories;
  - 38-3922-00 ~ Mold Cleaning Brush
  - 38-0306-00 ~ Card Cloth Brush
  - 38-0101-00 ~ Rasp

## BS-3

### TYPE MOLDS

*Horizontal Thru Bar to Horizontal Steel Surface*

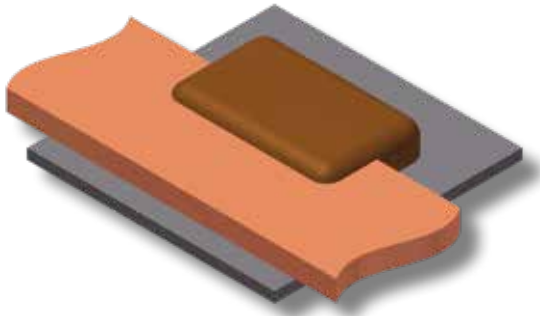

Bus Bar Size	Mold #	Price Key	Weld Metal	Handle Clamps	Lead Time
1/8 X 1	M-1088	4	115	B-106	4
1/8 X 1-1/2 & WIDER	M-1089	4	150	B-106	2
1/4 X 1	M-1090	4	150	B-106	4
1/4 X 1-1/4	M-1091	4	200	B-106	4
1/4 X 1-1/4 & WIDER	M-1092	4	250	B-106	4
3/8 X 1	M-1093	4	200	B-106	4
3/8 X 1-1/2 & WIDER	M-1094	4	250	B-106	4
1/2 X 1	M-1095	4	250	B-106	4
1/2 X 1-1/2 & WIDER	M-1096	5	2-200	B-107	4

Section 2 - Molds  
AWG Conductors

## BS-4 / BS-5

### TYPE MOLDS

*Horizontal or Vertical Thru Bar to Vertical Steel Surface*

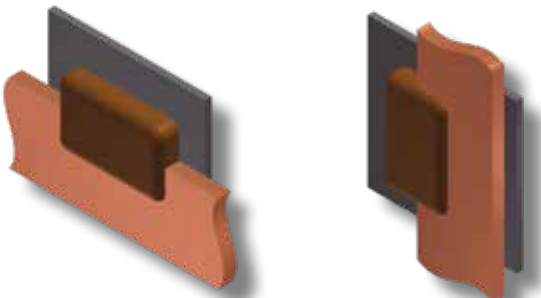

BS-4

BS-5

#### BS-4 MOLD

Bus Bar Size	Mold # BS-4	Price Key	Weld Metal	Handle Clamps	Lead Time
1/8 X 1	M-1054	4	115	B-106	4
1/8 X 2 & WIDER	M-1055	4	200	B-106	4
1/4 X 1	M-1056	4	150	B-106	2
1/4 X 2 & WIDER	M-1057	5	2-150	B-107	2
3/8 X 1	M-1058	4	200	B-106	4
3/8 X 2 & WIDER	M-1059	5	2-200	B-107	4
1/2 X 1	M-1060	4	250	B-106	2
1/2 X 2 & WIDER	M-1061	5	500	B-107	4

#### BS-5 MOLD

Bus Bar Size	Mold # BS-5	Price Key	Weld Metal	Handle Clamps	Lead Time
1/8 X 1	M-1063	4	115	B-106	2
1/8 X 2 & WIDER	M-1064	4	200	B-106	4
1/4 X 1	M-1065	4	150	B-106	2
1/4 X 2 & WIDER	M-1066	5	2-150	B-107	2
3/8 X 1	M-1067	4	200	B-106	4
3/8 X 2 & WIDER	M-1068	5	2-200	B-107	4
1/2 X 1	M-1069	4	250	B-106	4
1/2 X 2 & WIDER	M-1070	5	500	B-107	4

- For sizes not listed, contact thermOweld®.
- For heavy duty connections, contact thermOweld®.
- For expedited service, contact thermOweld®.
- To order weld metal for use with EZ Lite Remote® insert TW before and EZ after weld metal number.
- Required Tools;
  - Handle Clamps w/ Flint Ignitor (see chart for correct handles)
  - 38-0309-00 ~ Flint Ignitor or 38-EZLT-RU EZ Lite Remote®
- Other recommended accessories;
  - 38-3922-00 ~ Mold Cleaning Brush
  - 38-0306-00 ~ Card Cloth Brush
  - 38-0101-00 ~ Rasp



# CRE-1

## TYPE MOLDS

Horizontal Parallel Tap  
For AWG Conductors

MOLDS FOR AWG CONDUCTORS							
Rebar Size	Cable Size	Mold #	Packing Mat'l # See Note	Price Key	Weld Metal	Handle Clamps	Lead Time
#3	#6	M-7500	38-0329	4	25	B-106	2
	#4	M-7501	38-0329	4	32	B-106	2
	#2	M-7502	38-0329	4	45	B-106	2
	#1	M-7503	38-0329	4	65	B-106	2
	1/0	M-7504	38-0329	4	90	B-106	2
	2/0	M-7505	38-0329	4	90	B-106	2
	3/0	M-7506	38-0329	4	115	B-106	2
#4 & Larger	#6	M-7508	38-4061	3†	25	Included	2
	#4	M-7509	38-4061	3†	32	Included	2
	#2	M-7510	38-4061	3†	45	Included	2
	#1	M-7511	38-4061	3†	65	Included	2
#4	1/0	M-7512	38-0329	4	90	B-106	2
	2/0	M-7513	38-0329	4	90	B-106	2
	3/0	M-7514	38-0329	4	115	B-106	2
	4/0	M-7515	38-0329	4	115	B-106	2
#5	1/0	M-7520	38-0329	4	90	B-106	2
	2/0	M-7521	38-0329	4	90	B-106	2
	3/0	M-7522	38-0329	4	115	B-106	2
	4/0	M-7523	38-0329	4	115	B-106	2
#6 & Larger	1/0	M-7528	38-4062	14†	90	Included	2
	2/0	M-7529	38-4062	14†	90	Included	2
	3/0	M-7530	38-4062	14†	115	Included	2
	4/0	M-7531	38-4062	14†	115	Included	2

- For sizes not listed, contact thermOweld®.
- Molds listed are for concentric stranded cable. Add suffix "-S" to mold number for solid conductors.
- For heavy duty connections, contact thermOweld®.
- To order weld metal for use with EZ Lite Remote® insert TW before and EZ after weld metal number.
- For expedited service, contact thermOweld®.
- Required Tools;
  - Handle Clamps w/ Flint Ignitor (see chart for correct handles)
  - † ~ Sold complete with frame
  - 38-0309-00 ~ Flint Ignitor or 38-EZLT-RU EZ Lite Remote®
- Other recommended accessories;
  - 38-3922-00 ~ Mold Cleaning Brush
  - 38-0135-00 ~ Cable Cleaning Brush
  - 38-0304-00 ~ File

### REBAR PACKING

A packing material is necessary when making thermOweld® connections to Rebar. Be sure to specify Packing Material No. when ordering Mold and Weld Metal. Packing Material is either copper shim stock or ceramic fiber pad and can be used for **one** connection only.

- Part #38-0329-00 Copper Shim
- Part #38-4061-00 3" x 3" x 1/4"
- Part #38-4062-00 3" x 3" x 1/4"
- Part #38-4063-00 3" x 2 1/2" x 1/4"



Section 2 - Molds  
AWG Conductors

## CRE-2

### TYPE MOLDS

*Horizontal Cable Tap to Horizontal Rebar Run  
For AWG Conductors*

Section 2 - Molds  
AWG Conductors



#### MOLDS FOR AWG CONDUCTORS

Rebar Size	Cable Size	Mold #	Packing Mat'l # See Note	Price Key	Weld Metal	Handle Clamps	Lead Time
#3	#6	M-7588	38-0329	4	45	B-106	2
	#4	M-7589	38-0329	4	45	B-106	2
	#2	M-7590	38-0329	4	65	B-106	2
	#1	M-7591	38-0329	4	65	B-106	4
	1/0	M-7592	38-0329	4	90	B-106	2
	2/0	M-7593	38-0329	4	90	B-106	4
	3/0	M-7594	38-0329	4	115	B-106	2
#4	4/0	M-7595	38-0329	4	115	B-106	2
	#6	M-7596	38-0329	4	45	B-106	2
	#4	M-7597	38-0329	4	45	B-106	2
	#2	M-7598	38-0329	4	65	B-106	2
	#1	M-7599	38-0329	4	65	B-106	4
	1/0	M-7600	38-0329	4	90	B-106	2
	2/0	M-7601	38-0329	4	90	B-106	2
#5	3/0	M-7602	38-0329	4	115	B-106	2
	4/0	M-7603	38-0329	4	115	B-106	2
	#6	M-7604	38-0329	4	90	B-106	2
	#4	M-7605	38-0329	4	90	B-106	2
	#2	M-7606	38-0329	4	90	B-106	2
	#1	M-7607	38-0329	4	90	B-106	4
	1/0	M-7608	38-0329	4	115	B-106	2
#6	2/0	M-7609	38-0329	4	115	B-106	2
	3/0	M-7610	38-0329	4	150	B-106	2
	4/0	M-7611	38-0329	4	150	B-106	2
	#6	M-7612	38-0329	4	90	B-106	2
	#4	M-7613	38-0329	4	90	B-106	2
	#2	M-7614	38-0329	4	90	B-106	2
	#1	M-7615	38-0329	4	90	B-106	4
#6	1/0	M-7616	38-0329	4	115	B-106	2
	2/0	M-7617	38-0329	4	115	B-106	2
	3/0	M-7618	38-0329	4	150	B-106	2
	4/0	M-7619	38-0329	4	150	B-106	2

### REBAR PACKING

A packing material is necessary when making thermOweld® connections to Rebar. Be sure to specify Packing Material No. when ordering Mold and Weld Metal. Packing Material is either copper shim stock or ceramic fiber pad and can be used for **one** connection only.

- Part #38-0329-00 Copper Shim
- Part #38-4061-00 3" x 3" x 1/4"
- Part #38-4062-00 3" x 3" x 1/4"
- Part #38-4063-00 3" x 2 1/2" x 1/4"



- **For sizes not listed, contact thermOweld®.**
- Molds listed are for concentric stranded cable. Add suffix "-S" to mold number for solid conductors.
- For heavy duty connections, contact thermOweld®.
- For expedited service, contact thermOweld®.
- To order weld metal for use with EZ Lite Remote® insert TW before and EZ after weld metal number.
- Required Tools;
  - Handle Clamps w/ Flint Ignitor (see chart for correct handles)
  - 38-0309-00 ~ Flint Ignitor or 38-EZLT-RU EZ Lite Remote®
- Other recommended accessories;
  - 40-0319-01 ~ Mold Cleaner for cartridge sizes #15-#65
  - 40-0319-03 ~ Mold Cleaner for cartridge sizes #90-#500
  - 38-3922-00 ~ Mold Cleaning Brush
  - 38-0135-00 ~ Cable Cleaning Brush
  - 38-0304-00 ~ File

CRE-3

TYPE MOLDS

Horizontal thru Cable to Vertical Rebar  
For AWG Conductors

MOLDS FOR AWG CONDUCTORS							
Rebar Size	Cable Size	Mold #	Packing Mat'l # See Note	Price Key	Weld Metal	Handle Clamps	Lead Time
#3	#6	M-7620	38-0329	24	90	B-106	2
	#4	M-7621	38-0329	24	90	B-106	2
	#2	M-7622	38-0329	24	90	B-106	2
	#1	M-7623	38-0329	24	115	B-106	4
	1/0	M-7624	38-0329	24	115	B-106	4
	2/0	M-7625	38-0329	24	115	B-106	2
	3/0	M-7626	38-0329	24	150	B-106	2
	4/0	M-7627	38-0329	24	150	B-106	2
#4	#6	M-7628	38-0329	24	90	B-106	2
	#4	M-7629	38-0329	24	90	B-106	2
	#2	M-7630	38-0329	24	90	B-106	2
	#1	M-7631	38-0329	24	115	B-106	4
	1/0	M-7632	38-0329	24	115	B-106	2
	2/0	M-7633	38-0329	24	115	B-106	2
	3/0	M-7634	38-0329	24	150	B-106	2
	4/0	M-7635	38-0329	24	150	B-106	2
#5	#6	M-7636	38-0329	24	90	B-106	2
	#4	M-7637	38-0329	24	90	B-106	2
	#2	M-7638	38-0329	24	90	B-106	2
	#1	M-7639	38-0329	24	115	B-106	4
	1/0	M-7640	38-0329	24	115	B-106	2
	2/0	M-7641	38-0329	24	115	B-106	2
	3/0	M-7642	38-0329	24	150	B-106	2
	4/0	M-7643	38-0329	24	150	B-106	2
#6	#6	M-7644	38-0329	24	90	B-106	2
	#4	M-7645	38-0329	24	90	B-106	2
	#2	M-7646	38-0329	24	90	B-106	2
	#1	M-7647	38-0329	24	115	B-106	4
	1/0	M-7648	38-0329	24	115	B-106	2
	2/0	M-7649	38-0329	24	115	B-106	2
	3/0	M-7650	38-0329	24	150	B-106	2
	4/0	M-7651	38-0329	24	150	B-106	2
#7 & Larger	#6	M-7652	38-4063	4	90	B-106-41	2
	#4	M-7653	38-4063	4	90	B-106-41	2
	#2	M-7654	38-4063	4	90	B-106-41	2
	#1	M-7655	38-4063	4	115	B-106-41	4
	1/0	M-7656	38-4063	4	115	B-106-41	2
	2/0	M-7657	38-4063	4	115	B-106-41	2
	3/0	M-7658	38-4063	4	150	B-106-41	2
	4/0	M-7659	38-4063	4	150	B-106-41	2

- For sizes not listed, contact thermOweld®.
- Molds listed are for concentric stranded cable. Add suffix "-S" to mold number for solid conductors.
- For heavy duty connections or molds with wear plates, contact thermOweld®.
- For molds with wear plates, see page 135.
- For expedited service, contact thermOweld®.
- To order weld metal for use with EZ Lite Remote® insert TW before and EZ after weld metal number.
- Required Tools;
  - Handle Clamps w/ Flint Ignitor (see chart for correct handles)
  - 38-0309-00 ~ Flint Ignitor or 38-EZLT-RU EZ Lite Remote®
- Other recommended accessories;
  - 40-0319-03 ~ Mold Cleaner for cartridge sizes #90-#500
  - 38-3922-00 ~ Mold Cleaning Brush
  - 38-0135-00 ~ Cable Cleaning Brush
  - 38-0304-00 ~ File

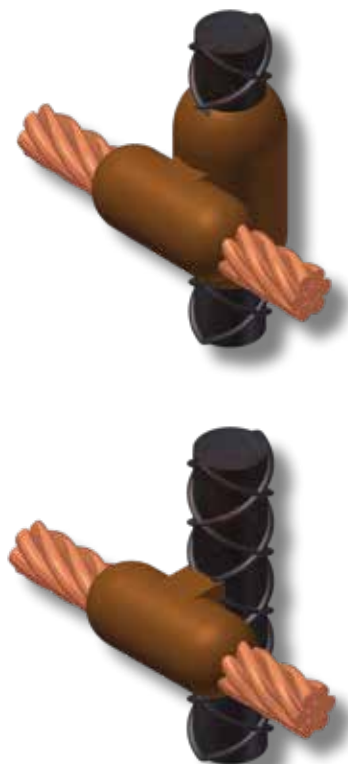

Section 2 - Molds  
AWG Conductors

REBAR PACKING

A packing material is necessary when making thermOweld® connections to Rebar. Be sure to specify Packing Material No. when ordering Mold and Weld Metal. Packing Material is either copper shim stock or ceramic fiber pad and can be used for **one** connection only.

- Part #38-0329-00 Copper Shim
- Part #38-4061-00 3" x 3" x 1/4"
- Part #38-4062-00 3" x 3" x 1/4"
- Part #38-4063-00 3" x 2 1/2" x 1/4"



## CRE-4

### TYPE MOLDS

*Horizontal thru Cable to Horizontal Rebar*  
For AWG Conductors

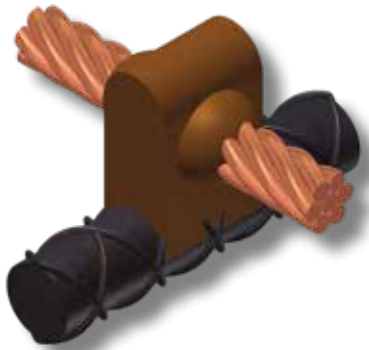
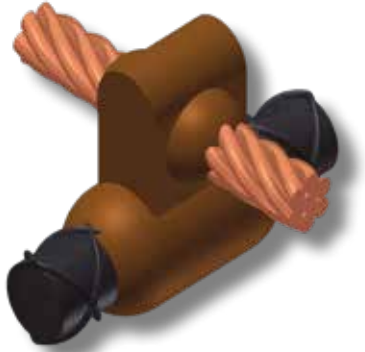

Section 2 - Molds  
AWG Conductors

MOLDS FOR AWG CONDUCTORS							
Rebar Size	Cable Size	Mold #	Packing Mat'l # See Note	Price Key	Weld Metal	Handle Clamps	Lead Time
#3	#6	M-7708	38-0329	4	65	B-106	2
	#4	M-7709	38-0329	4	65	B-106	4
	#2	M-7710	38-0329	4	90	B-106	2
	#1	M-7711	38-0329	4	90	B-106	2
	1/0	M-7712	38-0329	22	115	B-106	2
	2/0	M-7713	38-0329	22	115	B-106	2
	3/0	M-7714	38-0329	22	150	B-106	4
#4	#6	M-7716	38-0329	4	65	B-106	2
	#4	M-7717	38-0329	4	65	B-106	2
	#2	M-7718	38-0329	4	90	B-106	2
	#1	M-7719	38-0329	22	90	B-106	4
	1/0	M-7720	38-0329	22	115	B-106	2
	2/0	M-7721	38-0329	22	115	B-106	2
	3/0	M-7722	38-0329	22	150	B-106	2
#5	#6	M-7724	38-0329	4	65	B-106	2
	#4	M-7725	38-0329	4	65	B-106	2
	#2	M-7726	38-0329	4	90	B-106	2
	#1	M-7727	38-0329	22	90	B-106	4
	1/0	M-7728	38-0329	22	115	B-106	2
	2/0	M-7729	38-0329	22	115	B-106	2
	3/0	M-7730	38-0329	22	150	B-106	2
#6 & Larger	#6	M-7732	38-4061	14†	65	Included	2
	#4	M-7733	38-4061	14†	65	Included	2
	#2	M-7734	38-4061	14†	90	Included	2
	#1	M-7735	38-4061	14†	90	Included	4
	1/0	M-7736	38-4062	14†	115	Included	2
	2/0	M-7737	38-4062	14†	115	Included	2
	3/0	M-7738	38-4062	14†	150	Included	2
4/0	M-7739	38-4062	14†	150	Included	2	

### REBAR PACKING

A packing material is necessary when making thermOweld® connections to Rebar. Be sure to specify Packing Material No. when ordering Mold and Weld Metal. Packing Material is either copper shim stock or ceramic fiber pad and can be used for **one** connection only.

- Part #38-0329-00 Copper Shim
- Part #38-4061-00 3" x 3" x 1/4"
- Part #38-4062-00 3" x 3" x 1/4"
- Part #38-4063-00 3" x 2 1/2" x 1/4"



- For sizes not listed, contact thermOweld®.
- Molds listed are for concentric stranded cable. Add suffix "-S" to mold number for solid conductors.
- For heavy duty connections, contact thermOweld®.
- For molds with wear plates, see page 135.
- For expedited service, contact thermOweld®.
- To order weld metal for use with EZ Lite Remote® insert TW before and EZ after weld metal number.
- Required Tools;
  - Handle Clamps w/ Flint Ignitor (see chart for correct handles)
  - † ~ Sold complete with frame
  - 38-0309-00 ~ Flint Ignitor or 38-EZLT-RU EZ Lite Remote®
- Other recommended accessories;
  - 40-0319-03 ~ Mold Cleaner for PK-4 & 22 Molds w/cartridge sizes #90-#500
  - 38-3922-00 ~ Mold Cleaning Brush
  - 38-0135-00 ~ Cable Cleaning Brush
  - 38-0304-00 ~ File

# CRE-6

## TYPE MOLDS

Horizontal Cable Tap to Vertical Rebar  
For AWG Conductors

MOLDS FOR AWG CONDUCTORS							
Rebar Size	Cable Size	Mold #	Packing Mat'l # <small>See Note</small>	Price Key	Weld Metal	Handle Clamps	Lead Time
#3	#6	M-7884	38-0329	4	45	B-106	2
	#4	M-7885	38-0329	4	45	B-106	2
	#2	M-7886	38-0329	4	65	B-106	4
	#1	M-7887	38-0329	4	90	B-106	4
	1/0	M-7888	38-0329	4	115	B-106	2
	2/0	M-7889	38-0329	4	115	B-106	2
	3/0	M-7890	38-0329	4	150	B-106	2
	4/0	M-7891	38-0329	4	150	B-106	2
#4	#6	M-7892	38-0329	4	45	B-106	2
	#4	M-7893	38-0329	4	65	B-106	2
	#2	M-7894	38-0329	4	65	B-106	2
	#1	M-7895	38-0329	4	90	B-106	4
	1/0	M-7896	38-0329	4	115	B-106	2
	2/0	M-7897	38-0329	4	115	B-106	2
	3/0	M-7898	38-0329	4	150	B-106	2
	4/0	M-7899	38-0329	4	150	B-106	2
#5	#6	M-7900	38-0329	4	45	B-106	2
	#4	M-7901	38-0329	4	65	B-106	2
	#2	M-7902	38-0329	4	65	B-106	2
	#1	M-7903	38-0329	4	90	B-106	2
	1/0	M-7904	38-0329	4	115	B-106	2
	2/0	M-7905	38-0329	4	115	B-106	2
	3/0	M-7906	38-0329	4	150	B-106	2
	4/0	M-7907	38-0329	4	150	B-106	2
#6	#6	M-7908	38-0329	4	45	B-106	2
	#4	M-7909	38-0329	4	65	B-106	2
	#2	M-7910	38-0329	4	65	B-106	2
	#1	M-7911	38-0329	4	90	B-106	2
	1/0	M-7912	38-0329	4	115	B-106	2
	2/0	M-7913	38-0329	4	115	B-106	2
	3/0	M-7914	38-0329	4	150	B-106	2
	4/0	M-7915	38-0329	4	150	B-106	2
#7 & Larger	#6	M-7916	38-4063	4	45	B-106-32	4
	#4	M-7917	38-4063	4	65	B-106-32	2
	#2	M-7918	38-4063	4	65	B-106-32	2
	#1	M-7919	38-4063	4	90	B-106-32	2
	1/0	M-7920	38-4063	4	115	B-106-32	2
	2/0	M-7921	38-4063	4	115	B-106-32	2
	3/0	M-7922	38-4063	4	150	B-106-32	2
	4/0	M-7923	38-4063	4	150	B-106-32	2



Section 2 - Molds  
AWG Conductors

### REBAR PACKING

A packing material is necessary when making thermOweld® connections to Rebar. Be sure to specify Packing Material No. when ordering Mold and Weld Metal. Packing Material is either copper shim stock or ceramic fiber pad and can be used for **one** connection only.

- Part #38-0329-00 Copper Shim
- Part #38-4061-00 3" x 3" x 1/4"
- Part #38-4062-00 3" x 3" x 1/4"
- Part #38-4063-00 3" x 2 1/2" x 1/4"



- For sizes not listed, contact thermOweld®.
- Molds listed are for concentric stranded cable. Add suffix "-S" to mold number for solid conductors.
- For heavy duty connections, contact thermOweld®.
- For expedited service, contact thermOweld®.
- To order weld metal for use with EZ Lite Remote® insert TW before and EZ after weld metal number.
- Required Tools;
  - Handle Clamps w/ Flint Ignitor (see chart for correct handles)
  - 38-0309-00 ~ Flint Ignitor or 38-EZLT-RU EZ Lite Remote®
- Other recommended accessories;
  - 38-3922-00 ~ Mold Cleaning Brush
  - 38-0135-00 ~ Cable Cleaning Brush
  - 38-0304-00 ~ File



# SINGLE SHOT MOLDS

## REBAR SINGLE SHOT MOLDS

thermOweld® Single Shot Molds are an economical way to make cable connections to the top of a rebar. The Single Shot is a disposable single use ceramic mold that includes the weld metal and disc. Flint ignitor or EZ Lite Adapter (See page 81) must be purchased separately.

Section 2 - Molds  
AWG Conductors

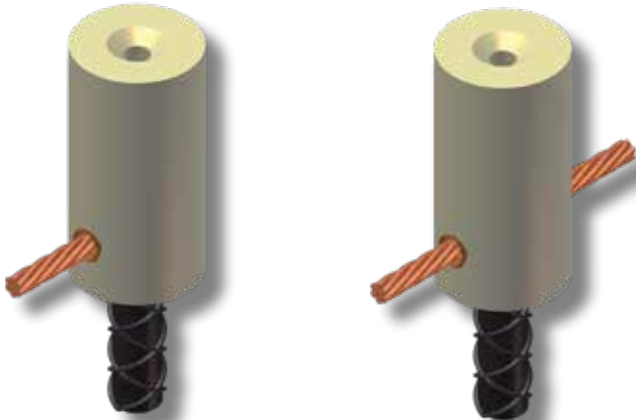

CRE-21

CRE-16

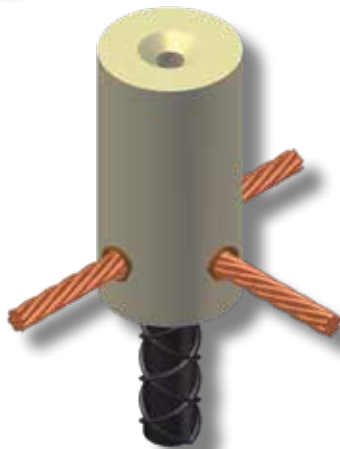

CRE-25



Rebar Size	Cable Size		Type	Mold #	Lead Time
	Solid	Stranded			
#3	#6, #8	#8	CRE-21	M-8929	4
	#3, #4	#4, #6	CRE-21	M-8930	4
	#1, #2	#2, #3	CRE-21	M-8931	4
	#6, #8	#8	CRE-16	M-8943	4
	#3, #4	#4, #6	CRE-16	M-8944	4
	#1, #2	#2, #3	CRE-16	M-8945	4
	#6, #8	#8	CRE-25	M-8955	4
	#3, #4	#4, #6	CRE-25	M-8956	4
	#1, #2	#2, #3	CRE-25	M-8957	4

Rebar Size	Cable Size		Type	Mold #	Lead Time
	Solid	Stranded			
#4	#6, #8	#8	CRE-21	M-8932	4
	#3, #4	#4, #6	CRE-21	M-8933	4
	#1, #2	#2, #3	CRE-21	M-8934	4
	2/0, 1/0	1/0, #1	CRE-21	M-8935	4
	N/A	2/0	CRE-21	M-8936	4
	#6, #8	#8	CRE-16	M-8947	4
	#3, #4	#4, #6	CRE-16	M-8948	4
	#1, #2	#2, #3	CRE-16	M-8949	4
	2/0, 1/0	1/0, #1	CRE-16	M-8950	4
	#6, #8	#8	CRE-25	M-8958	4
	#3, #4	#4, #6	CRE-25	M-8959	4
	#1, #2	#2, #3	CRE-25	M-8960	4
	2/0, 1/0	1/0, #1	CRE-25	M-8961	4

Rebar Size	Cable Size		Type	Mold #	Lead Time
	Solid	Stranded			
#5	#6, #8	#8	CRE-21	M-8937	4
	#3, #4	#4, #6	CRE-21	M-8938	4
	#1, #2	#2, #3	CRE-21	M-8939	4
	2/0, 1/0	1/0, #1	CRE-21	M-8940	4
	N/A	2/0	CRE-21	M-8941	4
	#6, #8	#8	CRE-16	M-8951	4
	#3, #4	#4, #6	CRE-16	M-8952	4
	#1, #2	#2, #3	CRE-16	M-8953	4
	2/0, 1/0	1/0, #1	CRE-16	M-8954	4
	#6, #8	#8	CRE-25	M-8962	4
	#3, #4	#4, #6	CRE-25	M-8963	4
	#1, #2	#2, #3	CRE-25	M-8964	4
	2/0, 1/0	1/0, #1	CRE-25	M-8965	4



# SINGLE SHOT MOLD

## EZ Lite Remote® Adapter

Follow steps 1 thru 10 in the Welding Instructions "Weld Procedures" that comes with the Single Shot Mold for proper installation of mold onto ground rod and how to place weld metal into mold.

Replace step 11 in the Welding Instructions "Weld Procedures" with the following;

11. Discard ceramic lid included with mold. Slide EZ Lite Remote® Single Shot Adapter over mold as shown.

Continue the instructions steps 12 through 14 in the Welding Instructions "Weld Procedures" that comes with the Single Shot Mold to complete weld.

Part Number: 38-EZLT-SS

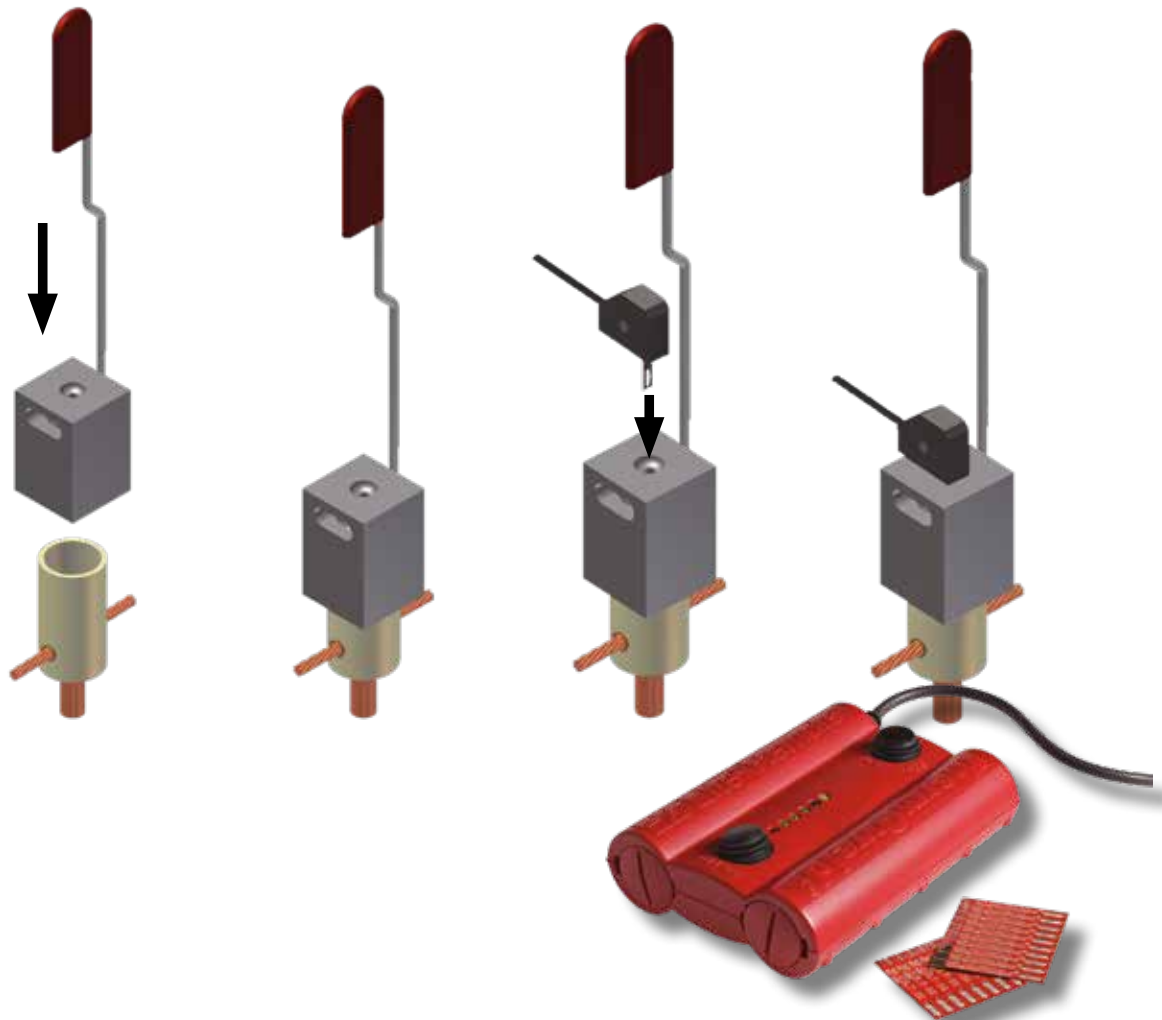



## SAME DAY SERVICE

(Grounding Market)

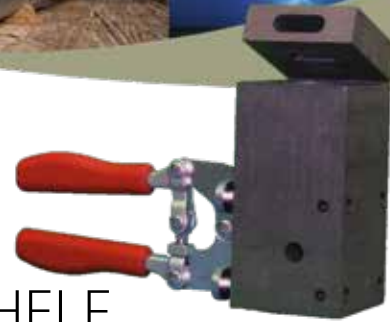

### JUST LIKE HAVING IT ON THE SHELF

Section 2 - Molds  
AWG Conductors

MOLDS			Single Shots	Weld Metal	Accessories
M-206	M-547	M-2540	M-2006	#15 Standard Weld Metal	B-106 Handle Clamp
M-208	M-548	M-2707	M-2008	#25 Standard Weld Metal	B-106 Vertical Handle Clamp
M-223	M-549	M-2781-S	M-2012	#32 Standard Weld Metal	Mini-Handle Clamp
M-223-S	M-550	M-5059	M-2013	#45 Standard Weld Metal	Flint Ignitors
M-228	M-559	M-5105	M-2014	#65 Standard Weld Metal	Steel Disc
M-232	M-560	M-5415-S	M-2015	#90 Standard Weld Metal	Mold Cleaner
M-235	M-561	M-6199	M-2017	#115 Standard Weld Metal	Natural Bristle Brush
M-236	M-647	M-6199-S	M-2018	#150 Standard Weld Metal	Shim Stock
M-241	M-588	M-6618-S	M-2021	#200 Standard Weld Metal	1 lb Packing Material
M-243	M-588-S	M-8718	M-2027	#250 Standard Weld Metal	Ceramic Fiber Packing
M-244	M-590	M-8833	M-2029	#500 Standard Weld Metal	1/8" x 1" Offset Copper Lug 1 Hole
M-246	M-591	M-9021	M-2032	#65 EZ Lite Remote® Weld Metal	1/8" x 1" Offset Copper Lug 2 Hole
M-247	M-593	M-9233	M-2107	#45 EZ Lite Remote® Weld Metal	1/4" x 1" Offset Copper Lug 1 Hole
M-280	M-630-S	M-9233-S		#90 EZ Lite Remote® Weld Metal	1/4" x 1" Offset Copper Lug 2 Hole
M-434	M-1276-S			#115 EZ Lite Remote® Weld Metal	1/4" x 1 1/2" Offset Copper Lug 1 Hole
M-443	M-1313-S			#150 EZ Lite Remote® Weld Metal	1/4" x 1 1/2" Offset Copper Lug 2 Hole
M-506	M-1322			#200 EZ Lite Remote® Weld Metal	Tin Plated Straight Lug
M-508	M-1331			#250 EZ Lite Remote® Weld Metal	Ez-Lite Remote® Ignitors
M-518	M-1587				Ez Lite Remote® Unit
M-545	M-1596				Ez Lite Remote® Starter Kit
M-545-S	M-2189				EZ Lite Remote® Single Shot Graphite Adapter
					6 ft Cable Assembly for EZ Lite Remote®

*Call Today  
Ship Today!*



**4PM**  
CENTRAL STANDARD  
TIME

\*SDS is not a guaranteed service. Quantities are limited.